

## (16) 各種緩衝材を設置した場合のトンネル抗口部の落石衝撃挙動解析

Numerical Simulation for Prototype Arch-shape Type RC Rock-shelter under falling weight impact loading

バティ アブドール カディール\*, 岸 徳光\*\*, 岡田 慎哉\*\*\*, 川瀬 良司\*\*\*\*, 千葉 知子\*\*\*\*\*

Abdul Qadir Bhatti, Norimitsu Kishi, Shin-ya Okada, Ryoji Kawase, and Tomoko Chiba

\*修(工) 室蘭工業大学大学院 博士後期課程 建設工学専攻 (〒050-8585 室蘭市水元町 27-1)

\*\*工博 室蘭工業大学 教授 建設システム工学科 (〒050-8585 室蘭市水元町 27-1)

\*\*\*修(工) 寒地土木研究所 研究員 寒地構造チーム (〒062-8602 札幌市豊平区平岸 1-3)

\*\*\*\*博(工) (株) 構研エンジニアリング 取締役 (〒065-8510 札幌市東区北 18 条東 17 丁目 1-1)

\*\*\*\*\* 室蘭工業大学大学院 博士前期課程 建設システム工学専攻 (〒050-8585 室蘭市水元町 27-1)

キーワード: トンネル抗口部, 三層緩衝構造, 伝達衝撃力, 衝撃応答解析  
(pithead of tunnel, three-layered absorbing system, transmitted impact force,  
elasto-plastic response analysis)

## 1. INTRODUCTION

In Japan, many reinforced concrete (RC) arch shelters have been constructed connecting to road tunnel to protect vehicles and people's lives from falling rocks [1,2,3]. However, usually those shelters have been designed without considering impact loads due to falling rocks. In order to establish a rational impact resistant design procedure for arch type RC rock-shelter based on not only allowable stress design but also ultimate state design and/or performance based design method, impact resistant capacity and/or maximum input impact energy for the RC structures must be clearly estimated. At present, the RC structures have been designed statically based on allowable stress design method.

Here, maximum input impact energy for reaching ultimate state was numerically estimated by means of three-dimensional elasto-plastic finite element method for existing real arch-type RC rock-shelters with sand-cushion and three-layered absorbing system under falling heavy-weight impact loading [4]. To effectively absorb and disperse the impact forces caused due to a rock falling, authors have developed a three layered absorbing system (TLAS) which is composed of 50 cm thick sand layer

(top), 20 ~ 30 cm thick Reinforced Concrete (RC) slab (core) and 50 ~ 100 cm thick Expanded Poly-Sterol (EPS) block (bottom) layer. For numerical analysis, LS-DYNA code was used [5]. The dimensions of the RC arch tunnel for numerical analysis are of 5,037 mm in inner radius, 7,891 mm in height of side-wall and 6,000 mm in length along the road which is one block of tunnel. 10,000 kg heavy-weight was used as falling weight. In this paper, falling height of heavy-weight was set as 20 m high. In this numerical analysis, solid elements were employed for concrete, falling heavy-weight and sand-cushion, and beam elements for rebar. Drucker-Prager and von Misses yield criteria were used as material constitutive law for concrete and rebar, respectively. Cracks were estimated by using smeared crack model by cutting-off the tensile stress at zero level when average tensile stress in element reaches at the tensile strength. In this paper, weight impact force, transmitted impact force to the roof of the tunnel, total axial force at each side wall, and displacement wave at the crown, and crack patterns of the shelter at the maximum displacement are output.

The results obtained from this study are as follows; 1) transmitted impact force is decreased to a half of impact force by applying TLAS; 2) it was observed that maximum

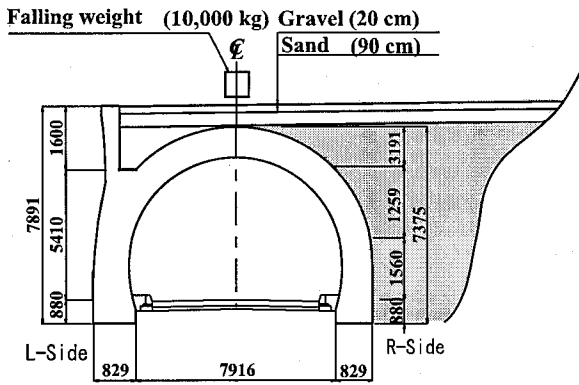

(a) Absorbing system with sand cushion

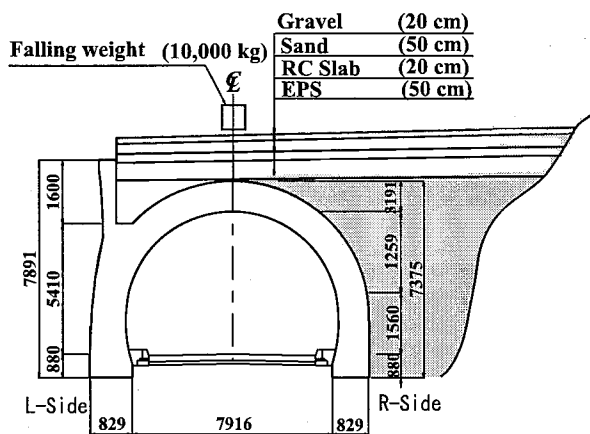

(b) Three layer absorbing system

Figure 1 RC Tunnel with two absorbing System

Table 1 Material Properties of two absorbing system

Material Type	Density	Elastic coefficient	Poisson's Ratio
	$\rho$ (kg/m <sup>3</sup> )	$E$ (GPa)	$\nu$
RC	2,500	25	0.2
Sand	1,600	10	0.06
Concrete	2,350	25	0.167
Rebar	7,850	210	0.3
EPS	20	0.0022	0
Foundation	2,000	0.042	0.45
Falling weight	3,054	210	0.3

response times of the impact force and displacement are different; 3) when TLAS is set up on the tunnel pithead part, the displacement can be decreased to about 3/4 at the crown compared with that the case setting sand cushion.

## 2. Outline of prototype arch shape type rock shelter and absorbing system

The cross-section and absorbing system of the RC arch are shown in **Figure 1**. In this figure, the D13 rebars for upper and lower axial ones are arranged taking 100 mm concrete cover. The shear rebars were not arranged. Material properties for each component for two absorbing system; sand cushion and TLAS, are listed in **Table 1**.

## 3. Analytical Overview

### 3.1 FE models

An example of FE numerical analysis model is shown in **Figure 2**. Only half of RC arch tunnel model, foundation, a falling heavy-weight, absorbing system: sand cushion; and TLAS were modeled with FE meshes considering symmetrical axis. Six and/or eight node solid elements were applied for all of these FE models except axial rebars. Total number of nodes and elements of the RC arch tunnel model of two absorbing systems shown in **Figure 2** are 60,470 and 63,389 for the case using sand cushion and 70,954 and 75,451 for the case using TLAS. The rebar arrangement of the RC arch tunnel is shown in **Figure 3**.

Numerical analyses models were precisely formed for each component based on the dimensions of the RC arch tunnel model used in the real prototype structure.

However, axial rebars have been simplified as a square element equivalent to an actual cross-sectional area. Contact surface is defined between striking face of heavy-weight and the upper surface of the absorbing system, in which sliding with contact and separation can be considered in this contact surface applied here. All nodes between concrete and rebar were assumed to be perfectly bonded with each other. Impact force is numerically surcharged against the RC arch tunnel model due to adding a predetermined impact velocity to all nodes of falling heavy-weight which is set on the surface of absorbing system. Impact response analysis for RC arch tunnel model was performed up to 300 ms from the beginning of impact. The time increment for numerical analysis is almost equal to 0.6 ms which is determined based on Courant stability condition.

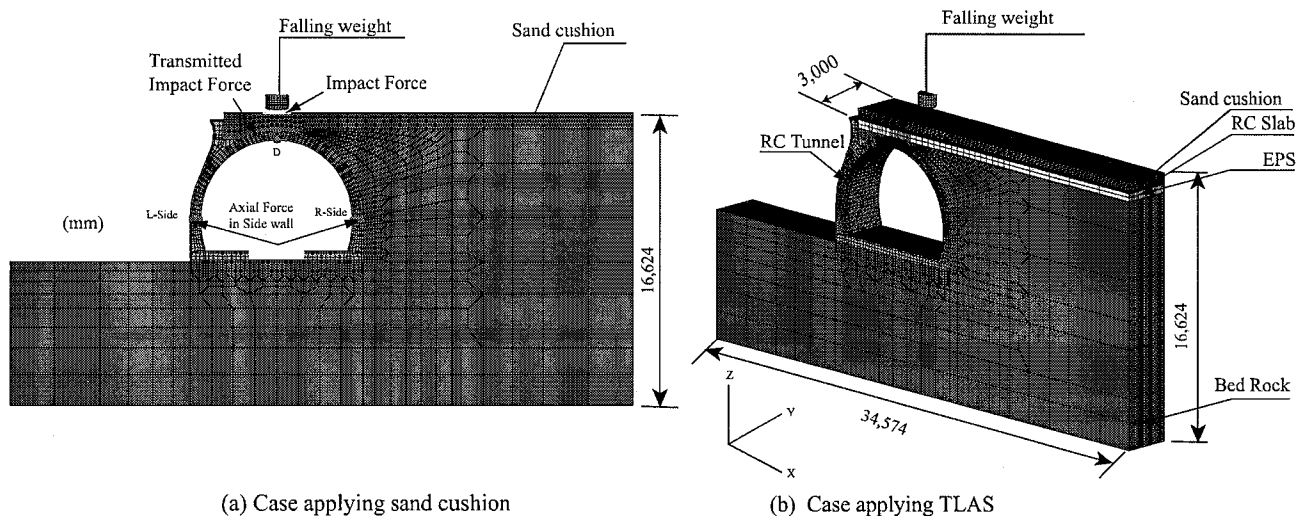

Figure 2 FE mesh model in cases applying two absorbing system

### 3.2 Modeling of materials

Figure 4 shows the stress-strain relations for each material: concrete; rebar; sand; and EPS block. Neither strain rate effects of all materials nor softening phenomenon of the post peak of concrete were considered for this elastoplastic impact response analysis. However, to accurately simulate a damped free vibration of the RC arch tunnel model after a heavy-weight rebounded, damping constant  $h$  was considered. The constitutive law for each material characteristics is briefly outlined below:

#### 3.2.1 Concrete

Stress-strain relation of concrete was assumed by using a bilinear model in the compression side and a cut-off model in the tension side as shown in Figure 4(a). It is assumed that: 1) yielding stress is equal to the compressive stress  $f'_c$ ; 2) concrete yields at 0.0015 strains; 3) the tensile stress is perfectly released when an applied pressure reaches the tensile strength of concrete; and 4) the tensile strength is set to be 1/10th of the compressive strength. von Mises criterion was applied to the yielding of concrete.

#### 3.2.2 Rebar

For rebars, an elasto-plastic model following isotropic hardening rule was applied as shown in Figure 4(b). Here, the plastic hardening modulus  $H'$  was assumed as 1 % of Young's modulus  $E_s$ . The yielding condition was judged based on von Mises criterion.

#### 3.2.3 Falling heavy-weight

Heavy-weight was modeled as elastic body based on ex-

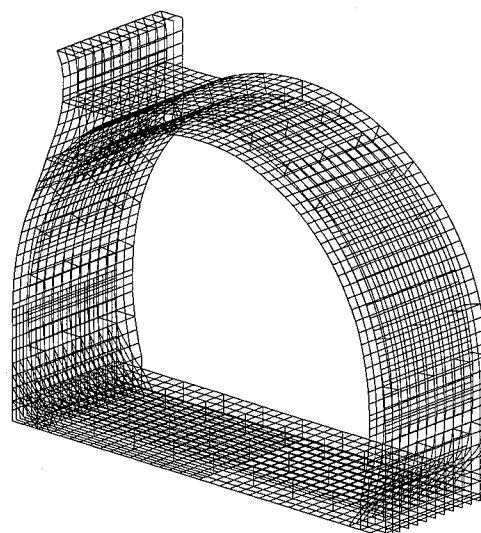

Figure 3 Rebar arrangement of tunnel

perimental observations. Young's modulus and Poisson's ratio were assumed as  $E_s = 206$  GPa and  $\nu_s = 0.3$  respectively.

#### 3.2.4 Sand cushion

Figure 4(c) shows the constitutive model for sand cushion. To rationally analyze in stress behavior of sand cushion when a heavy-weight collides on the cushion, second order parabolic stress-strain relation for sand cushion was assumed in which the constitutive relation is described in the following expression [6].

$$\sigma_s = 50\epsilon_s^2 \quad (1)$$

#### 3.2.5 Expanded Poly-Sterol (EPS) Block

Based on the concept as shown in Figure 4(d), it is as-

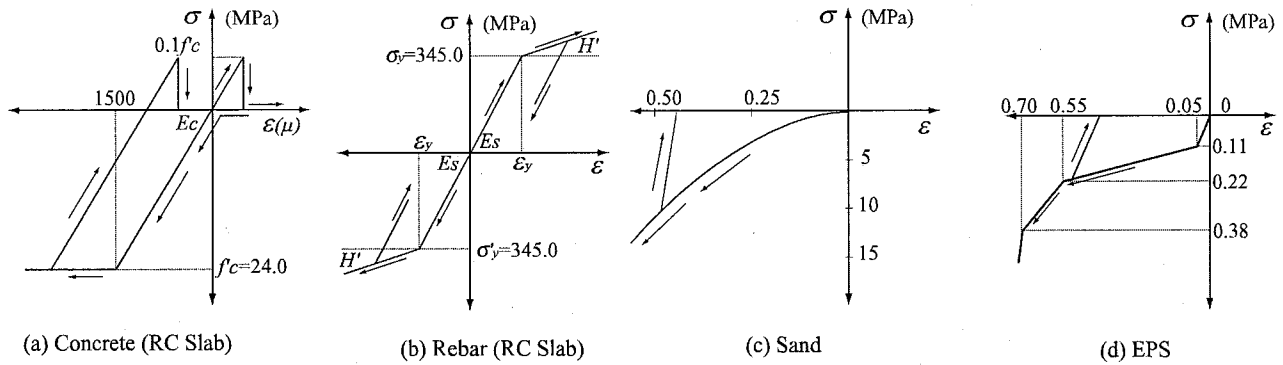

**Figure 4** Stress strain relationships of material constitutive models

sumed that the EPS layer will one-dimensionally behave against a collision of a falling rock in an effective area. The stress-strain relation of the EPS layer is multi-linearly modeled based on the curve obtained from the statical loading test with 10 mm/min loading speed.

In this paper, the maximum design strain of the EPS layer is limited to 0.55 to ensure an absorbing capacity of the TLAS and to keep some safety margin. [4]

#### (6) Strain rate effects and viscous damping constant

Neither strain rate effects of all material considered here nor softening phenomenon at post-peak of concrete were considered for impact response analysis of the RC arch tunnel models. In addition, to accurately simulate impact response characteristics of the models, a viscous damping constant  $h$  was considered. The value was assumed as  $h = 0.005$  for the lowest natural vibration mode.

### 4. Overview of analytical and experimental results

#### 4.1 Time histories of impact force and displacement at crown

The numerical analysis results for time histories of impact force ( $P$ ), transmitted impact force, estimated summing of response axial force at left and right hand side of wall and displacement at the crown ( $D$ ) of the RC tunnel model are compared between two cases of applying absorbing systems shown in **Figure 5**. The impact force ( $P$ ) obtained from the numerical analysis was estimated by summing the contact reaction forces in the vertical direction caused in the contact interface elements of falling heavy-weight.

From these figures, it can be observed that the impact

force wave ( $P$ ) is superposed of two waves: a triangular wave having 50 ms duration time; and a half-sinusoidal wave with 100 ms duration time for the case applying sand cushion; and an incidental triangular wave having 25 ms duration time and a half-sinusoidal wave with 100 ms duration time for the case applying TLAS as absorbing system. The configurations of the wave are almost similar for both absorbing systems. By comparing the response reaction forces at the side wall of left and right hand sides, it is observed that the two waves are almost similar to each other but higher frequency components are excited in the right hand side wall.

In addition, when paying attention to the transmitted impact force after falling weight collides, it is observed that maximum impact force in case applying sand cushion is 1.6 times larger than that of TLAS; and duration time of TLAS is about 50 ms longer than that of the case using sand cushion. By comparing the maximum response values of impact force and transmitted impact force, it is observed that the transmitted impact force is decreased to half and less of the impact force by using the TLAS and sand, respectively.

Focusing on the displacement ( $D$ ) shown in **Figure 6**, it is seen that the vibration period after reaching maximum amplitude and the damping characteristics are a little different between sand cushion and TLAS. However, wave configurations from the beginning of impact through the maximum value are almost similar to each other, irrespective of absorbing system. The maximum displacements for sand cushion and TLAS are about 13 and 11 mm, respectively. The RC tunnel model with TLAS vibrates with smaller residual displacement. On the other hand, it is ob-

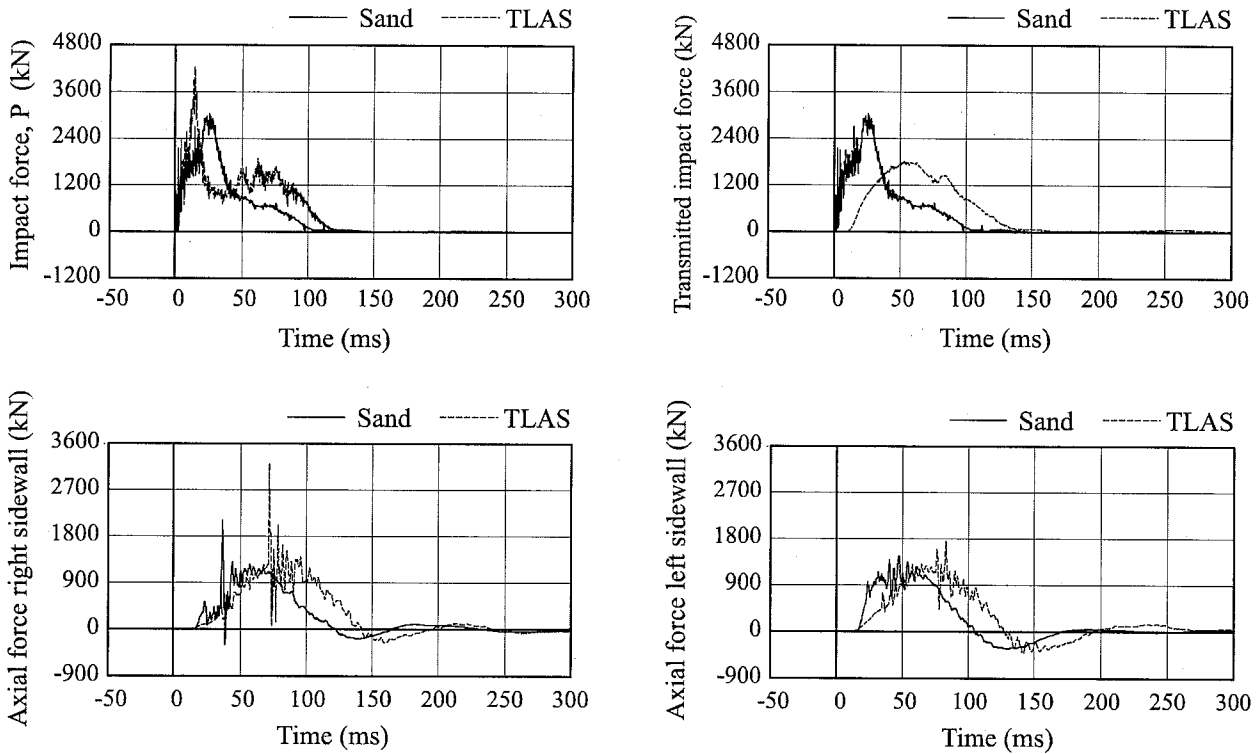

Figure 5 Comparison between two absorbing systems

served that the RC tunnel models vibrate with larger residual displacement and high damping after suffering severe damages in case of sand cushion. The residual displacements for sand cushion and TLAS are about 2 and 1 mm, respectively. The main reasons may be that in case of applying sand cushion, impact force will be concentrically loaded near the crown, but in case applying TLAS, the force will be depressively loaded over the whole of the tunnel.

#### 4.2 Crack patterns at maximum response displacement

Based on a constitutive law model assumed for concrete elements earlier, stress applied in the concrete elements will be converted to zero when the applied pressure in an element reaches the tension cut-off value. In other words, it is understood that the element with zero stress has a potential for crack occurring. Here, crack patterns can be predicted based on this concept.

Figure 7 shows the comparisons between the contours of the maximum principal stress at the maximum displacement for applying two absorbing systems. In those figures, white color stress contour means that the elements are around zero stress and crack will be occurred. From

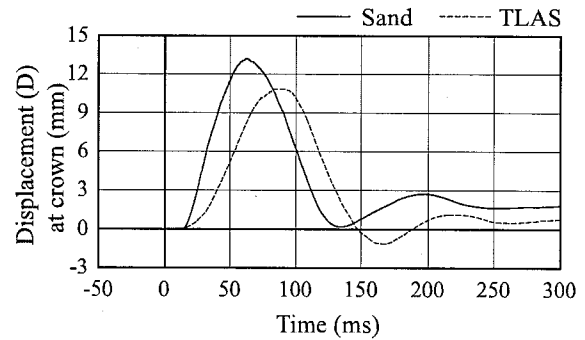
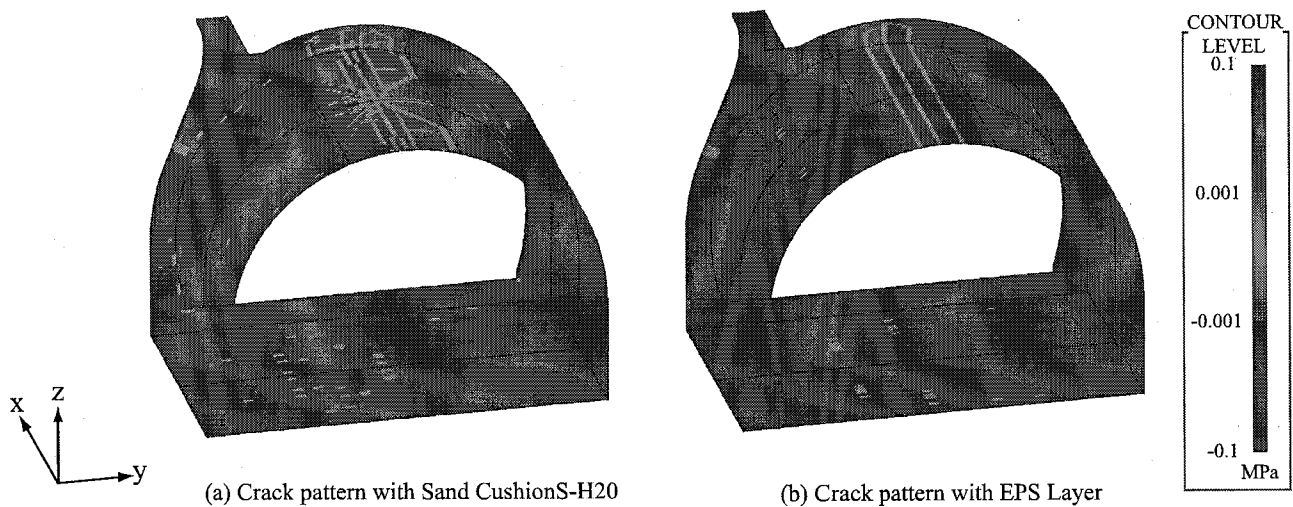

Figure 6 Displacement ( $D$ ) at crown of tunnel

those comparisons, it is observed that in case applying sand cushion, cracks are occurred near the loading points and that area was severely damaged; and in case applying TLAS, just three through crack along the tunnel axis were generated. From these results, it is confirmed that impact resistant capacity of the RC arch tunnel can be significantly upgraded apply TLAS as absorbing system.

#### 5. Conclusions

An applicability of the proposed FE technique was investigated for two absorbing system by performing the falling-weight impact loading simulation of prototype RC arch tunnel and by comparing with both results. The re-



**Figure 7** Crack Pattern of two absorbing system

sults obtained from this study are as follows:

- 1) Transmitted impact force is decreased to a half of impact force by applying TLAS;
- 2) It was observed that maximum response times of the impact force and displacement are different;
- 3) When TLAS is set up in the tunnel pithead part, the displacement can be decreased to about 3/4 at the crown compared with that the case setting sand cushion.
- 4) From the crack pattern, it is confirmed that impact resistant capacity of the RC arch tunnel can be significantly upgraded applying TLAS as absorbing system.

#### References

- [1] Kishi, N., Mikami, H., Matsuoka, K.G., and Ando, T. (2002) Impact behavior of shear-failure-type RC beams without shear rebar. *International Journal of Impact Engineering*, 27, 955-968.
- [2] Kawase, R, Konno, H., Ushiwatari, Y, and Kishi, N. (2003) Falling rock impact behavior analysis in pit-head tunnel with three layered absorbing system. *JCI* Vol.27, No.2, 871-876. (in Japanese)
- [3] Kawase, H, Kishi, N., Konno, H., and Okada, S. (2006) Numerical analysis research on impact response characteristic of small RC arch beam model, proceeding of *JCI*, Vol.28, No.2, 847-852. (in Japanese)
- [4] Kishi, N., H. Konno, and R. Kawase; Development of Three Layered Absorbing System for Rock-sheds. *Proceedings of IABSE*, Lisbon., 2005.
- [5] Hallquist, J.O., (2000) *LS-DYNA User's Manual*. Livermore Software Technology Corporation.
- [6] Bhatti A.Q, Kishi, N., OKADA S., KONNO H., "Impact Response Analysis of Large Scale RC Girder with Sand Cushion" Annual convention of Japan Concrete Institute (JCI), Vol. 28, No.2, pp. 871 ~ 876.