

Development of Simulation System of Spreading Fire Occurring Simultaneously in Many Places in an Earthquake Using Petri-net

Osamu Tsujihara¹, Kazuhiro Terada² and Tsutomu Sawada³

Abstract: The objective of this study is to develop the simulation system of spreading urban fire in an earthquake using Petri-net. A house is modeled by the 4 places and 12 transitions. The integral number which corresponds to the spreading time inside the house is allocated to each input arc. In order to represent the catching fire from next door, another transitions are prepared between the places which belong to the different houses. The integral number which corresponds to the spreading time of inter-house is allocated to the arc. It is demonstrated by numerical experiments that the simulation system can be applied to the case of fire which occurs simultaneously in many places.

Keywords : Petri-net, spreading fire, earthquake

1 . INTRODUCTION

Perfect fire fighting is not expected under the special circumstances such as urban fire in an earthquake. Simulation of spreading fire plays an important role to make the most use of the capacity of fire fighting. It is also practical and useful to evaluate the safety to a fire and to make a regional plan for disaster prevention.

Previous studies on the simulation of spreading fire are classified into the modeling of the mechanism of fire and its application to the urban area.

Formulas of spreading velocities of fire inside a house and between neighboring houses were proposed based on the researches of past fires and experiments. Hamada's formula¹⁾ of spreading velocity of fire is well known and had been used for the fire of wooden houses. Some other formulas have been proposed over since. TFD (Tokyo Fire Department)²⁾ proposed a new formula, which is called "Toshoshiki 97". The accuracy of spreading velocity of fire was remarkably improved through the research of damage of fire in 1995 Hyogo-ken Nanbu Earthquake. The influence of the collapse of houses was also reflected. Later, the TFD's formula was modified, so that fire-resistive and

quasi-fire-resistive types of houses can be managed. It is called "Toshoshiki 2001". This is one of the most reliable formulas of spreading velocity of fires.

Macro-simulation of spreading fire between grids (for example each grid is 5km × 5km mesh) over the urban area had generally been performed based on such information as the building coverage ratio. The improvement of the accuracy in the formula of spreading fire and development of GIS (Geographic information system) enabled *micro-simulation* of spreading fire between houses. Some researches on the *micro-simulation* of spreading fire in urban areas have been done. Yano, *et al.*³⁾ applied their original formula of spreading velocity of fire to the simulation of the fire in Kobe in 1995 Hyogo-ken Nanbu Earthquake. Sekizawa⁴⁾, *et al.* utilized the digital residential map for modeling the paths of spreading fire and they developed the system to perform the simulations with given wind velocity, wind direction and origin of fire. Tsujihara, *et al.*^{5,6)} also proposed the system to simulate urban fire in an earthquake in which the digital residential map was used. The advantage of this method is that the previous determination of paths of spreading fire is not necessary.

-
- 1) Member of JSCE, Dr. Eng., Associate Professor, Department of Civil Engineering, Wakayama National College of Technology (77 Noshima, Nada, Gobo, Wakayama 644-0023, JAPAN, E-mail: tsujihara@wakayama-nct.ac.jp)
 2) Member of JSCE, Student, Advanced Engineering Faculty, Wakayama National College of Technology
 3) Member of JSCE, Dr. Eng., Researcher, Professor, Department of Civil Engineering, The University of Tokushima

The paths are automatically determined depending on the conditions of wind direction and so on. However, it could not be applied to the simultaneously occurring fires, since the problem of spreading fire is formulated as the shortest route problem.

Petri-net (: e.g. Reising⁷⁾), defined in 1962 by Carl Adam Petri, is one of the useful mathematical representations to describe the concurrent behavior of a geographically distributed system. However, there are no examples in which Petri-net is introduced to the simulation of urban spreading fire.

The objective of this study is to develop the convenient simulation system of urban spreading fire in earthquakes, which is applicable to the simultaneously occurring fires, by introducing Petri-net.

2 . MODELING OF URBAN AREA

(1) Outline of Formula of Spreading Velocity of Fire

The formula of spreading velocity “Toshoshiki 2001” proposed by TFD is used in this study. The outline of the formula is mentioned in the followings.

The formula of the spreading velocity of fire is given to the wooden, wooden fire-preventive, quasi-fire-resistive and fire-resistive types of houses and buildings. Moreover the collapsed and partly collapsed houses can be considered. The spreading velocity of fire inside the wooden and wooden fire-preventive types is 52.1m/h and 42.8m/h, respectively. As to the quasi-fire-resistive and fire-resistive types, they are classified into 3 levels according to the usage of building and each spreading velocity is defined as the function of the size of building and the damage rate. The damage rate is related to the seismic intensity. The spreading velocity of fire between the houses or buildings is represented as the function of such parameters as seismic intensity and wind velocity. It varies with the combinations of types of constructions.

(2) Network Model of Urban Area

In order to apply the formula to the urban fire, the method was proposed by Tsujihara, *et al.*^{5,6)}, in which a house or building is modeled with 4 nodes and 6 links shown in Figure 1. The links are oriented lines. Since they have two ways, total number of links to express a house or building is actually 12. Spreading time of fire that is calculated with the spreading velocity, the length of link, wind velocity, wind direction and

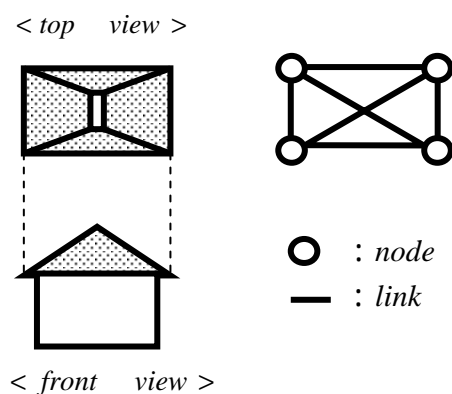

Figure 1 Modeling of a House

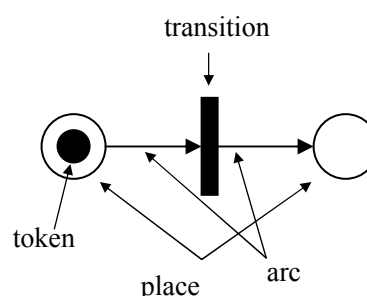

Figure 2 Petri-net

seismic intensity is allocated to each link. Links connecting the nodes of different houses are also set up. Spreading time of fire for the inter-house link is allocated in the same way.

3 . METHOD TO SIMULATE SPREADING FIRE USING PETRI-NET

(1) Petri-net

Petri-net consists of place (place nodes), transition (transition nodes), and directed arcs connecting places with transitions, which correspond to links, as shown in Figure 2. Each place can hold tokens. The distribution of tokens represents the state of a system. An arc may have the weights which are shown by the number of arrows or accompanying integral number (see Figure 3). A transition can *fire* if the number of tokens in the input place is as same as the weights of the connecting arc. Then, the tokens of the input place are consumed and a specified number of tokens are generated in the output place.

The advantage of Petri-net is that parallel operation is possible, so that computational efficiency is improved. Though Petri-net has been widely applied

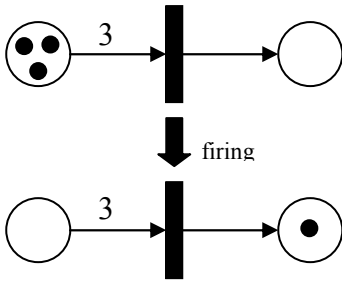

Figure 3 Firing of Transition

to engineering in general, there are few applications in civil engineering. There are some examples of applications to the simulation of traffic flow⁸⁾. However, no one has applied it to the simulation of urban spreading fire.

Another advantage of Petri-net is to be allowed to modify its rule. In the rule mentioned below, basic rule of Petri-net is modified.

(2) Modeling of Urban Area by Petri-net for Simulation of Spreading Fire

A house is modeled with 4 places. Arcs connect places with transitions. The spreading time of

fire, which can be calculated by TDF formula, is allocated as the weight of each arc. The arcs connecting the places which belong to different houses are also prepared with those weights calculated by TDF formula. Figure 4 shows an example of Petri-net modeling. Diagonal arcs inside the houses are actually prepared but not drawn in the figure.

Though Petri-net is known as a graphic model of asynchronous systems, the calculation in this proposed system is carried out step by step, since the concept of time is necessary in the simulation of spreading fire.

The rule of Petri-net used in this study is illustrated in the followings.

a) Rules of Analysis by Petri-net

The rules developed for the analysis of spreading fire is based on the colored Petri-net in which every token has the type. The three types of tokens in Table 1 are used. Let us explain the rule and the flow with Figure 5. The Petri-net model in Figure 5 has 3 places ($P=\{p_1,p_2,p_3\}$) and 2 transitions ($T=\{t_1,t_2\}$) and arcs. The initial marking is shown in Figure 5 (a), which indicates that p_1 is the place of initially burning. The token A is placed in p_1 . The place which holds the

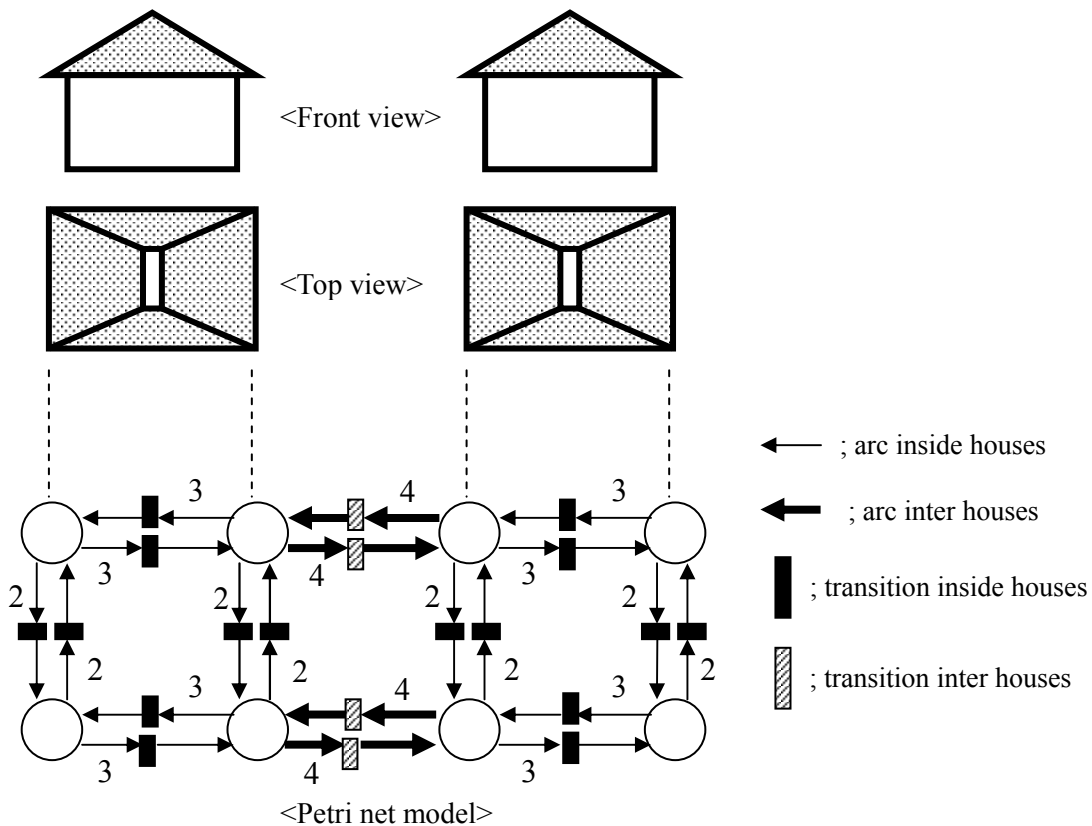

Figure 4 Petri-net Modeling for Simulation of Spreading Fire

Table 1 Types of Tokens and Their Roles

Shape	Name	Role
●	A	indicate burning
■	B	counter for <i>firing</i>
▲	C	indicate finishing <i>firing</i> from connected transitions

token A generates the token B in one (analytical) step. The one step corresponds to, for example, one minute. The place p_1 holds two tokens B after two steps as shown in Figure 5 (b). Then since the number of tokens B in p_1 equals to the weights of the arc to the transition t_2 , the copy of the token A moves to p_3 , but not consuming the tokens in p_1 as shown in Figure 5 (c). The place p_3 is to start burning after two steps; i.e., two minutes. After three steps, another token B is generated in p_1 , and the number of tokens B in it equals to the weights of the arc to the transition t_1 . Then the copy of the token A moves to p_3 as shown in Figure 5 (d). A token B is generated also in p_3 . In the step 3, all the output places from p_1 hold the token A, and p_1 generates a token C consuming the tokens B in it as shown in Figure 5 (e). Once a place holds a token C, it does not generate any tokens, nor does it accept them.

By memorizing the analytical step number when each place get a copy of token A, time to catch fire for each place is figured out. And by memorizing the number of place which sends a copy of token A, the paths of spreading fire can be identified.

b) Flow of Calculation in the Case of Simultaneously Occurring Fire

Let us illustrate the flow of calculation with Figure 6 in the case of plural origins of fire. The initial marking is shown in Figure 6 (a), which indicates that p_1 and p_{11} are the places of initially burning. The markings of the steps of 0,1,2,3,6 and 9 are shown in the figure. Time to catch fire for every place is shown in Table 2. Figure 7 illustrates it as well as the paths of spreading fire.

4 . SIMULATION OF SPREADING FIRE

Simulations of spreading fire are demonstrated by the method based on Petri-net mentioned in the previous chapter.

(1) Comparison with Conventional Method

The virtual city that consists of 30x30 houses is shown in Figure 8, which is used in the simulation. All

houses are supposed to be wooden and single-story.

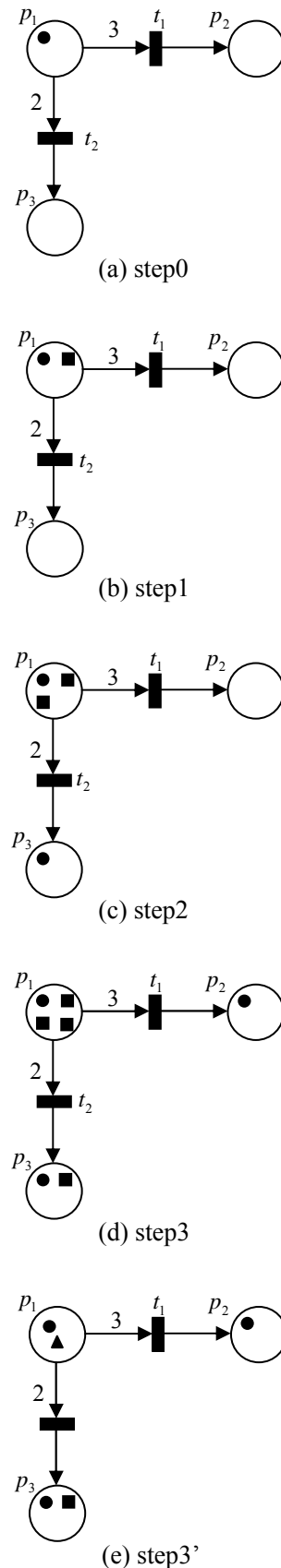
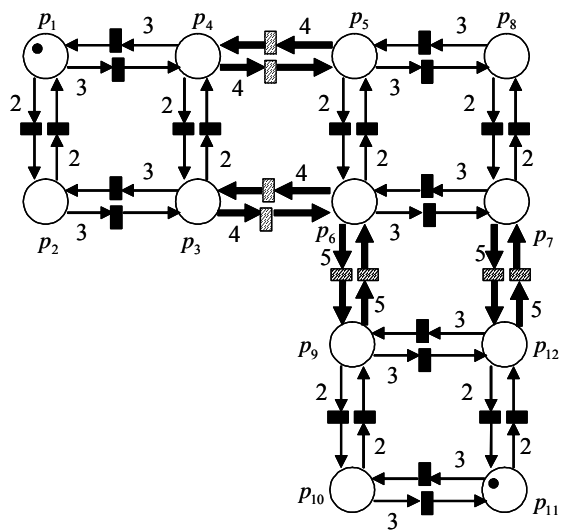
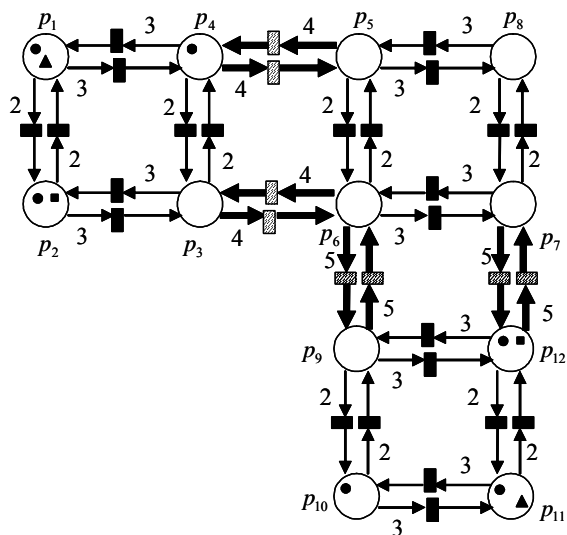

Figure 5 Marking in Colored Petri-net



(a) step0



(d) step3

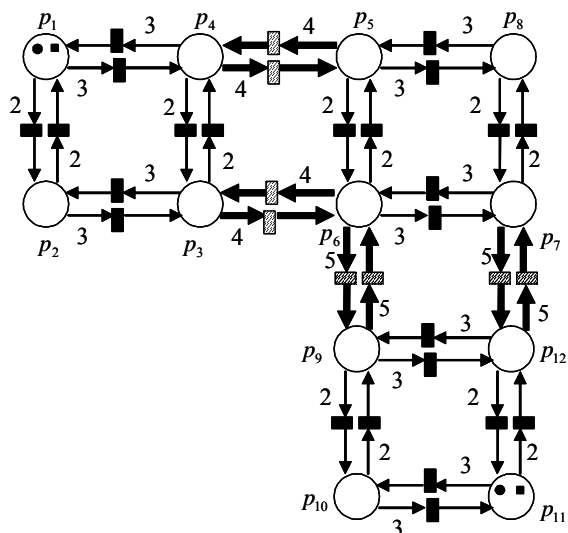

(b) step1

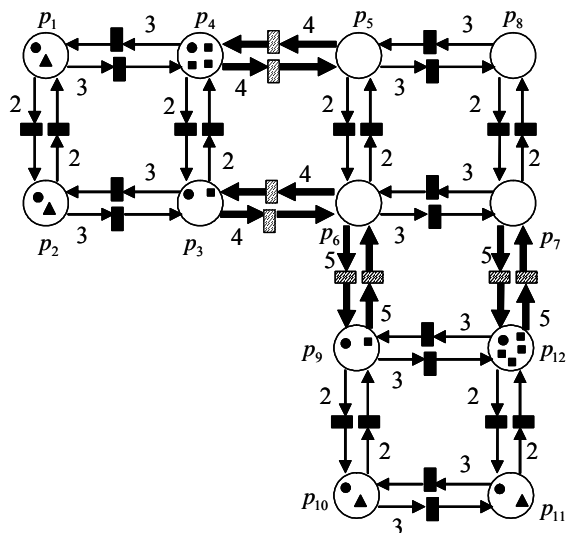

(e) step6

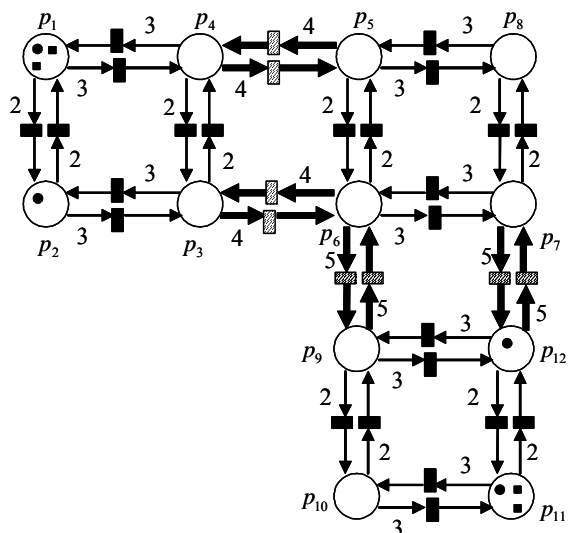

(b) step2

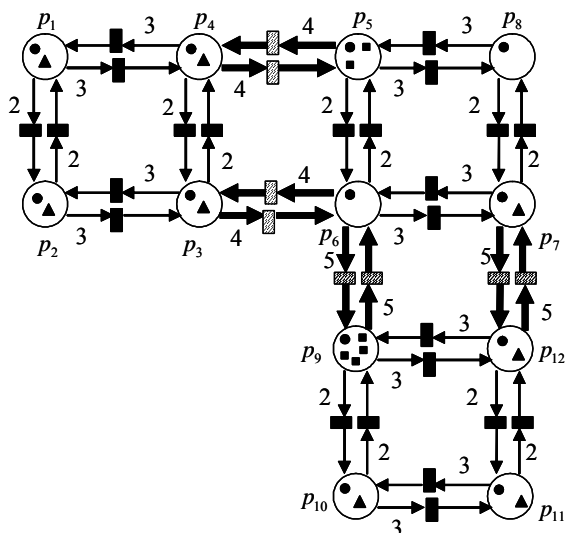

(f) step9

Figure 6 Markings of Step 0,1,2,3,6,9 in the Case of Plural Origins of Fire

Tabel 2 Arrival Time of Fire to Places

Place No.	Arrival time of fire (minute)	No. of place that send token A
1	0	-
2	2	1
3	5	2 or 4
4	3	1
5	7	4
6	9	3 or 5
7	7	12
8	9	7
9	5	10 or 12
10	3	11
11	0	-
12	2	11

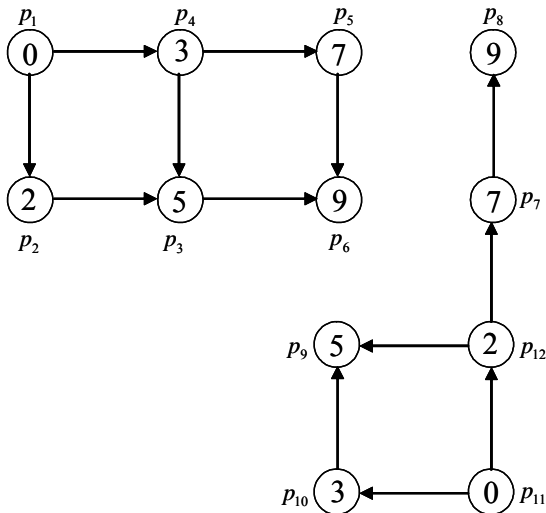

Figure 7 Paths of Spreading Fire and Arrival time of Fire

The plane shape of a house is square whose side length is 5m. The distance between the neighboring houses is 1m. The origin of fire is the place of lower left corner. The simulation is carried out under the condition of no wind and the seismic intensity scale of 6 lower by JMA (Japan Meteorological Agency). Figure 9 shows the results of simulations by the proposed and the conventional methods. The result of the conventional method^{5,6)} is the solution of the shortest route problem. The stage of 60, 120 and 180 minutes after fire breaks out. Though slight difference is recognized between the results of the simulations, they coincide with each other. Since the calculation is carried out in minutes in the Petri-net

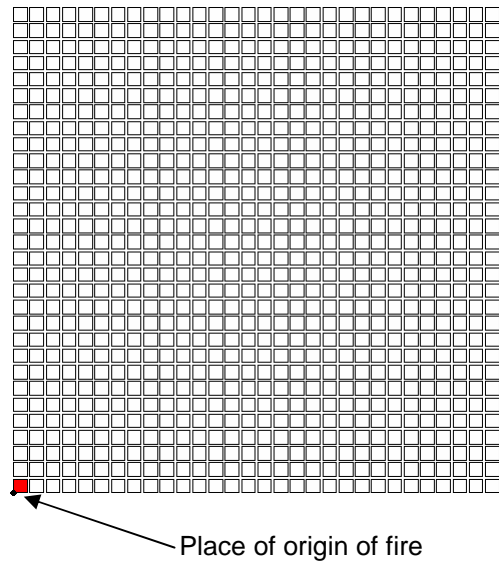

Figure 8 Virtual City and Place of Origin of Fire

simulation, the weight of each arc is rounded to minutes. The difference is caused by the round-off error. If the calculation is carried out in seconds, the difference of the results must be negligible. Taking into account of the accuracy of the formulas of spreading velocity of fire, however, the calculation in minutes should be adequate.

The computational time of simulations by the proposed and the conventional methods is both between one and two seconds except for time to read/write data from/on files. It is short enough, and the proposed method can be applied to the real-time prediction of spreading fire.

(2) Application to Simultaneously Occurring Fire

The conventional method, namely the solution of the shortest route problem, is effective. However, there are two insuperable difficulties in the application of the method to the simulation of plural origins of fire. One is to be forced to repeat calculations by the number of places of initially burning, which brings long computational time. Another one is that there is possibility to bring wrong solutions, because in the repeated calculations all of the places except that of origin of fire are regarded not to catch fire.

In the proposed method, on the other hand, the state of an arbitrary step of calculation can be handed over to the next step. Therefore, there is no fear to bring wrong solutions. Moreover, there is little increase of computational time according to the increase of origins of fire.

The results of the simulation are shown in Figure 10. Since fire breaks out simultaneously from 3 houses as

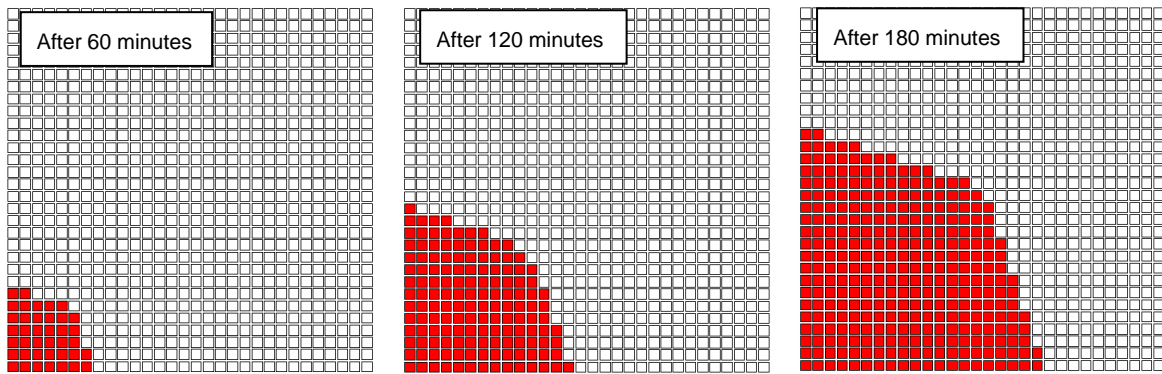

(a) Solutions by shortest route problem

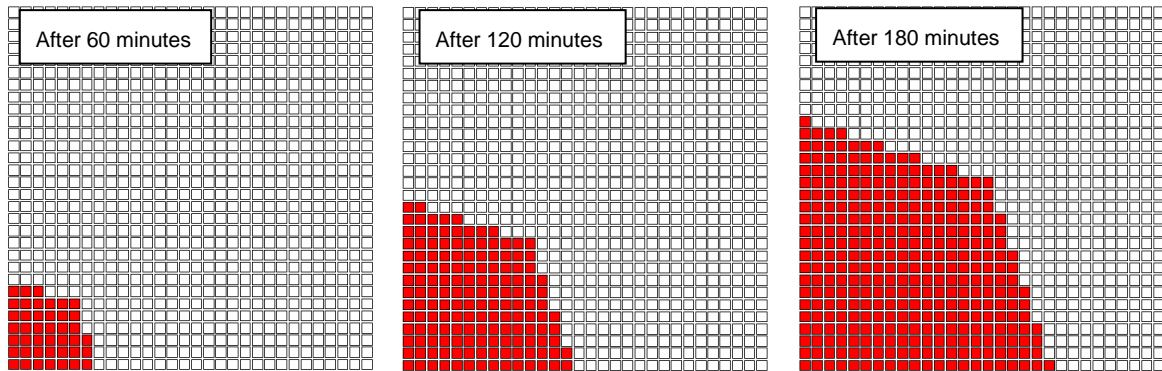

(b) Solutions by Petri-net

Figure 9 Comparison of Results of Simulations

shown in the figure (a), total of 12 paces are origins of fire. Other conditions of the simulation are identical to those in the case of single origin of fire. The stage of 60, 120 and 180 minutes after fire breaks out in the figure. The state in which the fire enlarges with the centers at the origins of fire can be expressed. Thus, the validity of the proposed method based on Petri-net was confirmed through some numerical experiment.

This method is also applicable to the simulation of fire which breaks out with time lag.

5 . CONCLUSIONS

A simulation system of spreading urban fire in an earthquake is developed using Petri-net. The major results are as follows.

1) The simulation system of spreading urban fire in an earthquake is developed using colored Petri-net. A house is modeled by 4 places and 12 transitions. The spreading time inside the house, which is calculated by TDF formula and is rounded to integer, is allocated to each input arcs. The transitions between the places which belong to the different houses are also set up. Simulation of spreading

urban fire was successfully carried out using the Petri-net model.

- 2) Compared with the conventional method in the case of single origin of fire, the performance of the proposed method was good.
- 3) It is demonstrated that the proposed method could be applied to the simulation in the case of plural origins of fire, though it was difficult to solve such the problem by the conventional method.

The simulation in the actually damaged area in the fire needs to be performed to discuss the validity of the proposed method in the future studies.

REFERENCES

- 1) Tokyo Fire Department, URL: <http://www.tfd.metro.tokyo.jp/eng/index.html> (last date accessed: 9 November 2005).
- 2) Handbook of fire, *Japan Association for Fire Science and Engineering*, Kyoritsu Shuppan Co. Ltd., 1997 (in Japanese).
- 3) Yano, K., Matsui, T., Takaki, H., Bouike, M. and

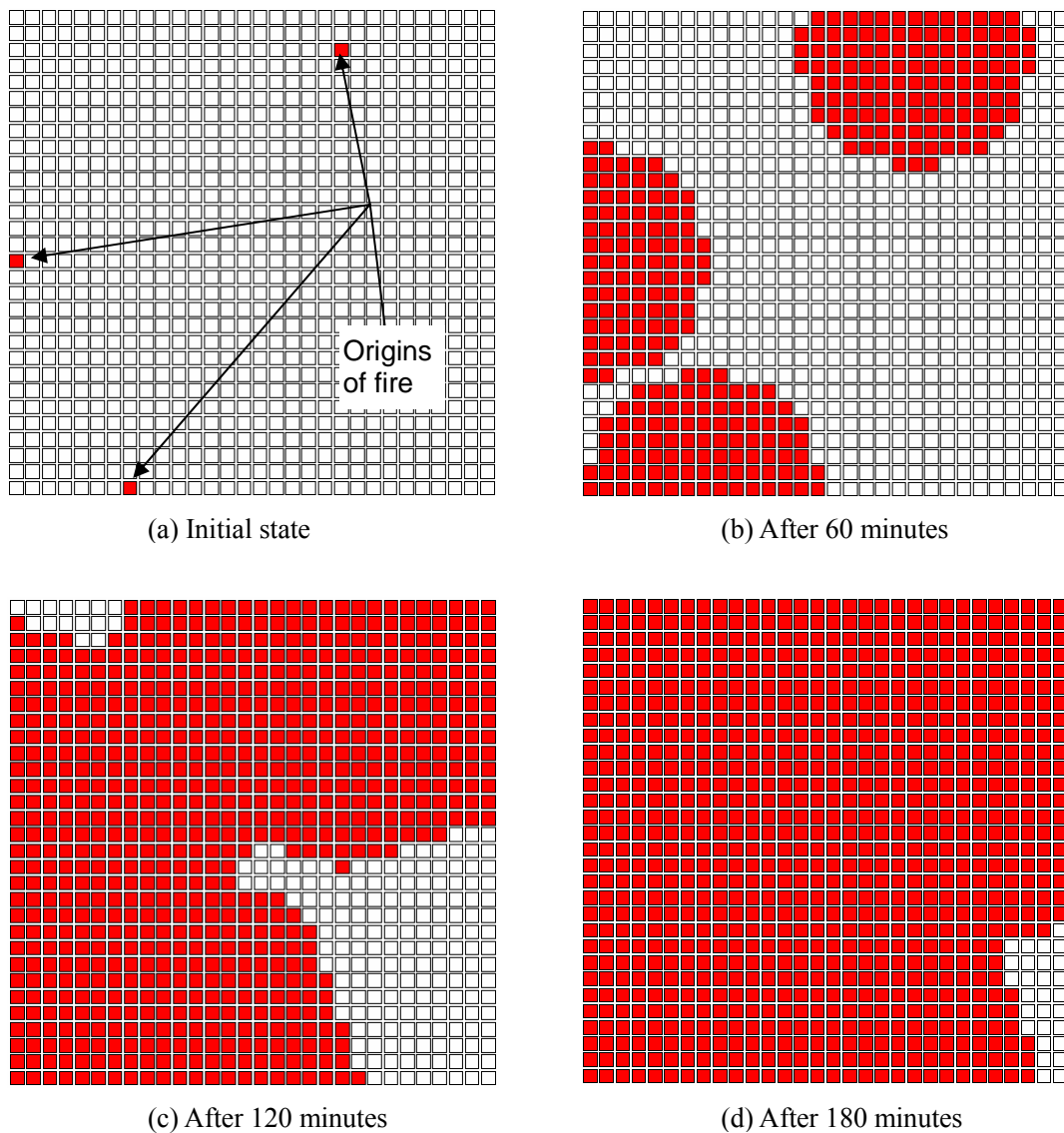

Figure 10 Results of Simulation in the Case of Simultaneously Occurring Fire

- Uemura, Y., Study on simulation model of large fires spread caused by Kobe Earthquake, *Proceedings of Infrastructure Planning*, No.19(2), pp.39-42, 1996(in Japanese).
- 4) Sekizawa, A., Takahashi, K., Endo, M., Zama, S., Yanase, T., Shinohara, H. and Sasaki, K., Information system for supporting Fire-fighting Activities based on real time fire spread simulation, *Proceedings of Institute of Social Safety Science*, No.11, pp.117-120, 2000(in Japanese).
 - 5) Tsujihara, O., Fushimi, Y., Kubori, T., Sawada, T., Construction of convenient simulation system of spreading fire at an earthquake using digital residential maps, 2003, *Journal of Applied Computing in Civil Engineering*, pp.237-244, 2003 (in Japanese).
 - 6) Tsujihara, O., Fushimi, Y., Kubori, T., Sawada, T. and Mitsuiwa, Y., Simulation system of spreading fire in an earthquake using digital residential maps, *Proceedings of 13th World Conference on Earthquake Engineering*, Paper No. 3386, pp.1-12, 2004.
 - 7) Reising, W., *A Primer in Petri Net Design*, Springer-Verlag, 1992.
 - 8) Kimata, N., Kisino, K. and Siromizu, Y., Development of practical software for micro traffic flow Petri net simulator, *Journal of Applied Computing in Civil Engineering*, Vol.9, pp.31-40, 2000.