

RETROFITTING FATIGUE-CRACKED JOINTS BY TIG ARC REMELTING

By Chitoshi MIKI, Takeshi MORI**, Satoshi TUDA*** and Kenji SAKAMOTO*****

The TIG arc remelting procedure was applied to retrofitting fillet-welded joints with fatigue cracks at weld toes. Fatigue tests was performed on as-welded joints and on retrofitted joints in order to verify the effect of this procedure, and the growth of fatigue cracks was analyzed using a fracture mechanics approach. Experimental and analytical results show that the fatigue lives of cracked joints are greatly improved by TIG arc remelting when the cracks have been completely remelted. When the cracks were not successfully remelted, the fatigue lives of retrofitted joints were influenced by layer thickness of remelted zone and size of remaining crack.

Keywords : TIG arc remelting, fatigue crack, fracture mechanics

1. INTRODUCTION

Fatigue cracks formed at toes of fillet welds of steel bridge members are often coped with gouging, rewelding, and then finishing by grinding, and further, spliced by steel plates with bolts or welds. However, there is risk of members being deformed and floor slab concrete adversely affected if a large amount of welding is performed, or when stress distributions are changed by adding plates there would be a possibility of new fatigue cracks being induced. Consequently, depending on the cause of fatigue crack occurrence or the degree of damage, there are cases when it would be desirable for only the crack portion to be repaired preserving the original state as much as possible. In addition, when numerous cracks of the same kind occur, it is desirable for their repairs to be as simple as possible, and moreover, of low cost.

A study is made here through experiments and fracture mechanics analyses of the retrofitting effects on joints with fatigue cracks originated from the surfaces of toes of fillet welds by performing Tungsten Inert Gas (TIG) arc remelting, completely or partially remelting the cracks. TIG remelting is usually used to finish weld toes to smooth shapes by melting the toes with nonconsumable tungsten electrodes. Attempts to improve fatigue strengths by TIG remelting of fillet weld toes have been made with offshore structures principally the objects, and the effectiveness of this procedure is a matter that has been confirmed^{1,2)}. The cost of this is said to be about one-fifteenth of grinder finishing and the working time about one-sixth³⁾. Retrofitting of fatigue-cracked joints by TIG remelting of the kind considered here has been done by Fisher et al.^{4,5)} on fatigue damage which occurred at the ends of cover plates of Yellow Mill Pond Bridge in the

* Member of JSCE, Dr. Eng., Associate Professor, Department of Civil Engineering, Tokyo Institute of Technology (O-okayama, Meguro-Ku, Tokyo)

** Member of JSCE, M. Eng., Research Associate, Department of Civil Engineering, Tokyo Institute of Technology

*** Graduate Student, Tokyo Institute of Technology

**** Member of JSCE, Honshu-Shikoku Bridge Authority (Toranomon, Minato-ku, Tokyo)

United States.

2. METHOD OF TESTING

The configurations and dimensions of the specimens are shown in Fig. 1. Attachment plates were fixed to main plates by fillet welding. The specimens were of the two types, FB with the attachment plate welded across the width of the main plate and SB with the attachment plate welded in the longitudinal direction. The steels used were SM58 for main plates and SM50 for attachment plates. The mechanical properties and chemical compositions of the steel plates for specimens are given in Table 1. Welding was done manually using low hydrogen type electrodes.

The fatigue tests were performed by four-point bending as shown in Fig. 2 using an electrohydraulic servo-type fatigue testing machine of dynamic capacity 50 kN. The stress waveform was sinusoidal, and the rate of stress repetition was 10 to 20 Hz. The stress ratio was made approximately 0.1 in all tests.

In order to retrofit a fatigue crack, it is necessary for deep fusion to be obtained in a stable manner. The conditions for TIG arc remelting as given in Table 2 were set up in this case based on the results of preliminary tests using flat plates. Fusion to depths of 3 to 4 mm could be expected with these conditions. The position aimed at by the electrode was set at 0 to 1 mm from the toe of the weld as shown in Fig. 3 based on the results of preliminary tests using fillet welded joints similar to those of the FB type specimens.

3. IMPROVEMENT OF TOE SHAPE BY TIG ARC REMELTING

Fig. 4 shows macroscopic photographs of the fillet weld toe before and after TIG arc remelting. The toe has been made very smooth by the remelting. The curvature radius ρ and the flank angle θ at the toe of the weld were measured on FB-type specimens with the purpose of quantitatively defining the shapes of these toes. Measurements were made using dental impression material to obtain molds of toes. The desired

Table 1 Mechanical Properties and Chemical Compositions of Steels.

material	mechanical properties			chemical compositions (%)								
	yield strength (MPa)	tensile strength (MPa)	elongation (%)	C	Si	Mn	P	S	Cu	Ni	Cr	V
				x 100	x 1000	x 100						
SM58	590	680	32	13	22	145	11	4	1	1	3	-
SM50	410	560	28	16	37	140	25	5	-	-	-	4

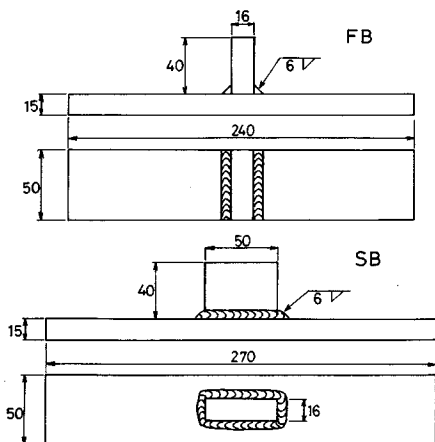

Fig. 1 Configurations and Dimensions of Specimens.

Table 2 TIG Arc Remelting Condition.

polarity	direct current, electrode negative
electrode	thoriated tungsten
flow rate of argon	10 l/min
current	230 A
speed	10 cm/min

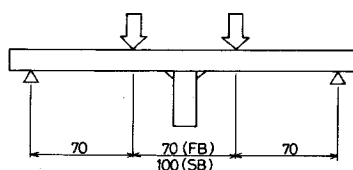

Fig. 2 Four Point Bending Fatigue Test.

locations were cut out from these molds in thicknesses of about 0.5 mm, and measurements were taken in enlarging the cut mold to 20 times using a magnifying projector. The results were that $\rho \doteq 0.7$ mm and $\theta \doteq 120$ deg. for as-welded specimens and $\rho \doteq 5.0$ mm and $\theta \doteq 120$ deg. for specimens subjected to TIG arc remelting, all of these being average values.

The stress distributions in the direction of plate thickness at cross sections including toes of welds were calculated by two-dimensional finite element analyses for as-welded FB specimens and FB specimens on which TIG arc remelting had been performed. The analyses were made assuming plane strain, with the minimum size of element as 0.025 mm. Fig. 5 shows stress distributions in the direction of plate thickness obtained by FEM analyses. The "as-welded" indicates the stress distribution at the cross section of as-welded specimens where the stress on the surface is the maximum. "TIG-MAX" indicates the stress distribution at the cross section of specimen subjected to TIG remelting where maximum stress was originated, while "TIG-CR" indicates the stress distribution at the cross section where stress was maximum in as-welded specimens, that is, the cross section where fatigue cracks occurred and grew in the as-welded state. The distance between the locations of "TIG-MAX" section and "TIG-CR" section is about 0.8 mm, and the stress distributions in these two sections are almost similar.

The stress concentrations at the surface (maximum stress determined by finite element analysis divided by the nominal bending stress at the surface) were 2.5 with as-welded joints and 1.4 with joints on which TIG arc remelting had been performed, and it is clear that stress condition is prominently improved by the remelting.

4. TEST RESULTS

The results of fatigue tests on as-welded specimens are shown in Fig. 6. The ordinate in the figure gives the nominal bending stress range S_r , and the abscissa gives the number of stress cycles to failure N_f (fatigue life). Fig. 7 is an illustration of beach marks observed, while Fig. 8 shows the relationship between crack depth (a) and fraction of life (n/N_f) obtained from the results of beach mark observations. In accordance with these results, the stress range was made 280 MPa for the tests to produce fatigue cracks in FB-type specimens and the numbers of cycles of loading were made 350 000 cycles corresponding to 90 percent of averaged fatigue life and 450 000 cycles corresponding to 110 percent. With SB-type specimens, the stress range was also made 280 MPa, but with the cycles of loading from 300 000 to 350 000 cycles (approximately 85 to 100 percent of averaged fatigue life). It is estimated from Fig. 8 that cracks of depths from about 2 to 6 mm were formed at 90 percent of the life.

Specimens loaded up to the specified number of cycles were subjected to dye penetrant tests (PT) and ultrasonic tests (UT) to ascertain the shapes and dimensions of fatigue cracks. The results of these tests are given in Table 3. With these non destructive inspection methods there were specimens in which fatigue cracks were not detected. In some of the specimens, fatigue cracks had already gone through in the

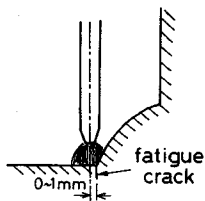

Fig. 3 Position Aimed at by TIG Arc Remelting.

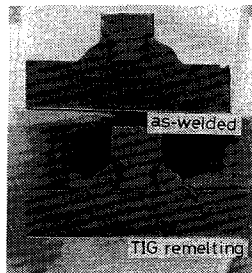

Fig. 4 Macroscopic Photographs of the Fillet Weld Toes.

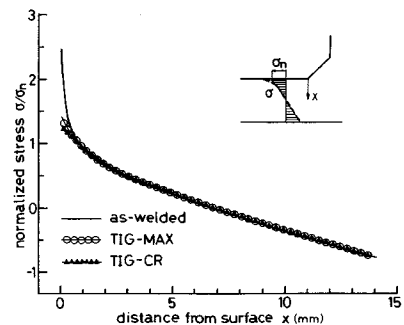

Fig. 5 Stress Distribution in the Direction of Plate Thickness at the Weld Toe.

direction of width, and the depth had reached to about one-half of the plate thickness.

There were many cases in which observed values differed between PT and UT, and it is thus considered necessary for studies to be made of detection and measurement methods which are high in accuracy.

The fatigue test results of specimens retrofitted by TIG arc remelting are shown in Fig. 9 and Table 3. The fatigue lives indicated are those according to the number of cycles in retesting after remelting, and the

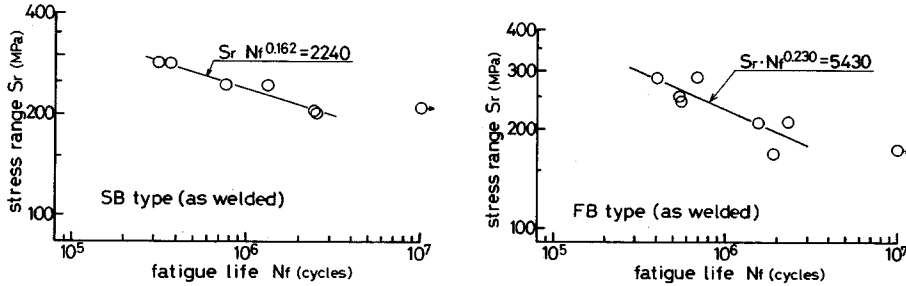

Fig. 6 Fatigue Test Results of As-Welded Specimens.

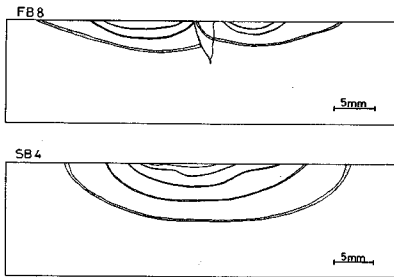

Fig. 7 Beach Marks on the Failure Surfaces of As-Welded Specimens.

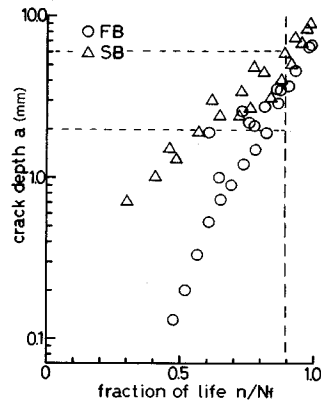

Fig. 8 Relationship between Crack Depth and Fraction of Fatigue Life.

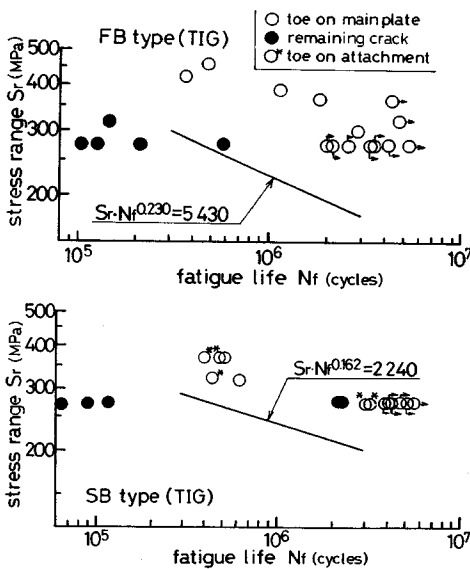

Fig. 9 Fatigue Test Results of Retrofitted Specimens.

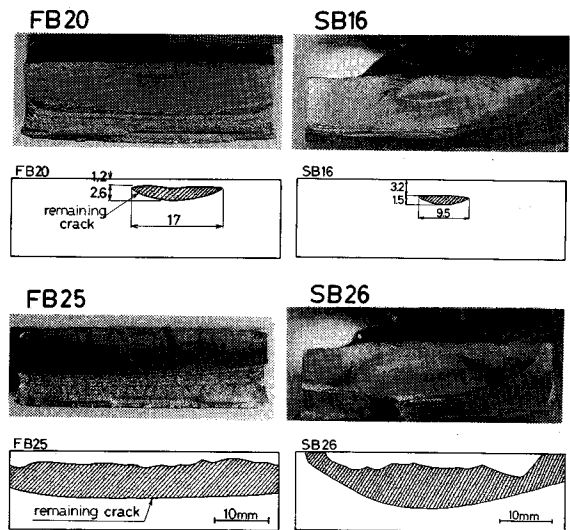

Fig. 10 Failure Surfaces of Retrofitted Specimens.

Table 3 Fatigue Test Results of Retrofitted Specimens.

specimen	stress range (MPa)	fatigue life (cycles)	size of remaining crack 2a x 2b (mm)**	thickness of fused layer d (mm)**	crack size obtained by nondestructive test***	
					PT, 2b (mm)	UT, a x 2b (mm)
FB 6	456	476 650	-	-	-	-
FB 7	275	>5 400 000	-	-	4, 23	-
FB 9	275	>3 500 000	-	-	2, 6	-
FB 10	302	2 871 340	-	-	10	3.1 x 31
FB 12	366	>4 200 000	-	-	-	-
FB 14	366	1 822 520	-	-	-	-
FB 15	421	362 360	-	-	-	-
FB 17	321	>4 700 000	-	-	-	-
FB 18	275	>2 600 000	-	-	35	3.6 x 20
FB 19	385	1 137 090	-	-	-	-
FB 20	275	582 000	2.6 x 17.0	1.2	2	4.8 x 20
FB 21	275	>2 100 000	-	-	-	-
FB 22	275	>2 000 000	-	-	-	-
FB 23	275	>3 340 000	-	-	-	3.2 x 10
FB 24	275	103 000	7.5 x 50.0	1.7	50	10 x 50
FB 25	275	125 680	7.0 x 50.0	1.6	50	9.6 x 50
FB 27	275	>4 050 000	-	-	2	-
FB 28	275	207 790	5.0 x 33.0	1.8	32	5.9 x 30
FB 29	275	9 980	7.5 x 50.0	1.1	50	8.8 x 50
FB 31	316	145 160	4.0 x 33.0	1.6	37	3.3 x 28
SB 5	320	438 000*	-	-	-	X
SB 6	366	515 000	-	-	-	X
SB 8	275	>5 000 000	-	-	2, 3	X
SB 10	365	394 000*	-	-	-	X
SB 11	274	3 300 000*	-	-	3	X
SB 12	274	116 000	7.3 x 48.0	2.1	48	X
SB 13	274	>5 600 000	-	-	2	X
SB 15	278	>4 690 000	-	-	3, 3	X
SB 16	274	2 150 000	1.5 x 9.5	3.2	10	X
SB 20	274	70 800	5.0 x 34.0	2.8	32	X
SB 21	317	625 000	-	-	-	X
SB 22	274	2 229 000	2.7 x 12.1	2.0	4, 4	X
SB 24	275	>4 160 000	-	-	7, 4	X
SB 25	271	3 050 000*	-	-	2	X
SB 26	271	89 000	8.7 x 48.0	2.1	48	X
SB 27	274	55 000	5.4 x 48.5	5.0	49	X
SB 28	274	>4 200 000	-	-	2, 2	X
SB 30	274	>3 880 000	-	-	3	X
SB 31	365	486 000*	-	-	-	X

* the fatigue crack which originated at the toe on the surface of attachment plate ** see Fig.12(b)
 *** see Fig.12(a) PT ; penetrant test UT ; ultrasonic test X ; ultrasonic test was not performed.

number of stress cycles to produce the fatigue cracks are not included. The solid marks in Fig. 9 indicate the results with specimens confirmed to have cracks that had been created in the primary tests before TIG arc remelting. When fatigue cracks had been completely fused by TIG arc remelting, fatigue strength of the specimen was greatly increased as a matter of course. The results of the experiments also show that some degree of fatigue life could be expected even when it had not been possible for cracks to be completely remelted by TIG arc and cracks had remained inside.

The asterisks in the figure indicate data on locations of crack occurrence which were not at toes of welds on main plates, but toes on the surface of attachment plates (SB type only). This is thought to have been because whereas toe shape on the main plate had been significantly improved by TIG arc remelting, the toe shape on the attachment plate was unaltered from that when welded, and the condition was relatively severe against the attachment plate with regard to fatigue. The effectiveness of retrofitting by TIG arc remelting can be comprehended from this also.

Examples of failure surfaces of specimens on which TIG arc remelting was performed and some portion of crack were remained are given in Fig. 10. In all of the cases the surface portions of cracks have been fused by TIG arc remelting. A fatigue crack of approximately 2.6 by 17 mm had remained in Specimen

FB 20 that had possessed a fatigue life roughly the same as the as-welded joint. A crack of 1.5 by 9.5 mm had remained in Specimen SB 16, but the fatigue life was extended about six-fold compared with as-welded specimens. Even in cases such as Specimens FB 25 and SB 26 where cracks had reached to more than one-half of plate thickness, and with the cracks in the condition of having been provided with lids by the remelting process, fatigue lives of about one fifth of as-welded specimens were possessed.

The thicknesses of fused layers formed by TIG remelting were about 1 to 3 mm, and were thinner than the fused layers ascertained by flat plates. The reasons for this are thought to be that crack location and the location where fused depth becomes maximum do not coincide, and the fused depth differs when a crack exists. It will be necessary for further study to be made concerning the accurate detection of fatigue crack and the working conditions to obtain a stable, deep fusion at the cracked portion.

5. ANALYSIS OF FATIGUE CRACK PROPAGATION LIFE

With FB-type specimens as the objects, the fatigue life retrofitting effect due to improvement of weld toe profile and fusing the crack by TIG arc remelting were estimated by fatigue crack growth analysis using fracture mechanics.

(1) Fatigue Crack Propagation Behavior

As shown in the beach mark observation results of Fig. 7, cracks of semi-elliptical shape initiated along the toes of welds in as-welded specimens, and the cracks grew in semi-elliptical shape. Fig. 11 (a) shows observation results of beach marks on failure surface of a specimen subjected to TIG arc remelting in which cracks had been completely fused, while Fig. 11 (b) shows observed beach marks on a specimen in which cracks by primary test had remained. It is clear from the beach marks that when cracks had been completely fused, fatigue cracks initiated along toes of welds similarly to as-welded specimens and had grown in semi-elliptical shape. On the other hand, when cracks had remained, since beach marks were not clear at parts fused through TIG arc remelting (above the remained cracks), the propagation properties there were indistinct, but since the shapes of beach marks below the remained crack and the type of loading were of bending, it is estimated that cracks first started to grow mainly from the upper tip of the remained crack and extended to the surface. After having reached the surface the crack was semi-elliptical in shape.

(2) Stress Intensity Factor Range

The ranges of stress intensity factors, ΔK_A and ΔK_B , at Point A of the leading edge in the direction of depth and Point B of the leading edge in the direction of width, respectively, of a semi-elliptical-shape fatigue crack in a joint as-welded and a joint with cracks completely refilled through TIG arc remelting (see Fig. 12 (a)) were obtained by the following^{(6)~(9)} :

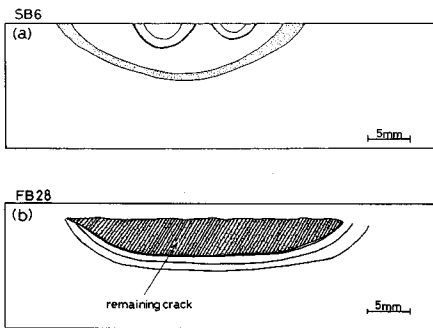

Fig. 11 Beach Marks on Failure Surfaces of Retrofitted Specimens.
 (a) crack was completely fused,
 (b) crack was not successfully fused

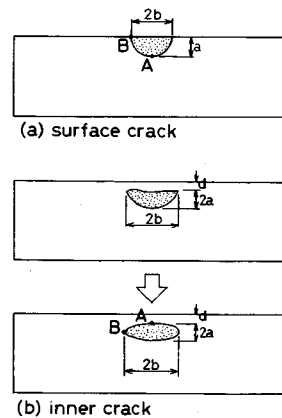

Fig. 12 Simplification of Fatigue Crack for Calculation of Stress Intensity factor.

$$\left. \begin{aligned} \Delta K_A &= F_{eA} \cdot F_{SA} \cdot F_{LA} \cdot F_{GA} \cdot S_r \sqrt{\pi a} \\ \Delta K_B &= F_{eB} \cdot F_{LB} \cdot F_{GB} \cdot S_r \sqrt{\pi a} \end{aligned} \right\} \dots\dots\dots (1)$$

A crack which was remained inside of plate after TIG arc remelting was simplified as a elliptical crack as shown in Fig. 12 (b), and the ranges of stress intensity factors were determined by the following :

$$\left. \begin{aligned} \Delta K_A &= F_{eA} \cdot F_{LA} \cdot F_{el} \cdot F_{GA} \cdot S_r \sqrt{\pi a} \\ \Delta K_B &= F_{eB} \cdot F_{LB} \cdot F_{GB} \cdot S_r \sqrt{\pi a} \end{aligned} \right\} \dots\dots\dots (2)$$

Where, F_{eA} and F_{eB} are correction factors for crack configurations, F_{SA} is that for surface crack, F_{LA} and F_{LB} are those for the thickness and width of plate. F_{el} is a correction factor for the fact that a crack exists close to the surface and is eccentric in relation to the direction of depth. F_{GA} and F_{GB} are correction factors in relation to stress concentrations in a joint. In the calculation of F_{GA} and F_{GB} , the "as-welded" curve for the as welded specimens, the "TIG-MAX" curve for specimens with a crack completely fused by TIG arc remelting, and the "TIG-CR" curve for specimens with a crack remaining was used in Fig. 5, respectively.

(3) Crack Growth Analysis

The following relationship between crack propagation rate (da/dN) and stress intensity factor range (ΔK)^{10, 11} is used for the analyses of fatigue crack growth.

$$da/dN = 5.4 \times 10^{-9} (\Delta K^3 - \Delta K_{th}^3) \dots\dots\dots (3)$$

da/dN : mm/cycle, ΔK : MPa \sqrt{m} , ΔK_{th} : threshold value of fatigue crack proagation

Since the vicinity of the weld toe where a crack initiates and starts to grow may be considered as a residual tensile stress field, the ΔK_{th} for as-welded joints and joints at which cracks were completely fused by TIG arc remelting was taken to be the 2 MPa \sqrt{m} . As for ΔK_{th} in case a crack had remained, since it was conceivable that the residual stress in the vicinity of the edge of the remaining crack would be alleviated by fusion due to remelting and even become compressive depending on the case, the value 8 MPa \sqrt{m} was taken.

For as-welded joints and in which cracks were completely fused by TIG arc remelting, the existence at weld toes of semi circular surface cracks of radii 0.05 mm was assumed. This was because it has been confirmed that it can be expected for cracks of such dimensions to be formed at the beginning (see Fig. 8), and because growth of cracks of this degree of size produced in the welded joint can be expressed by eq. (3)^{12, 13}. The crack remaining after TIG arc remelting is assumed to elliptical form as in Fig. 12 (b) and the ratio of minor axis to major axis is taken as 0.15 on the basis of experimental results.

The crack depth when the joint would fail was taken to be 50 percent (7.5 mm) of plate thickness. As shown in Fig. 8, 95 percent or more of the life has been finished when crack depth has reached 7.5 mm.

(4) Results of Analyses

The results of analyses on fatigue crack propagation lives of as-welded joints and joints with cracks completely fused by TIG arc remelting are shown in Fig. 13 together with results of experiments. The analysed results are somewhat on the short life side compared with experimental results. However, the analysed results also indicate that alleviation of stress concentration by TIG remelting will lead to substantial improvement in fatigue strength.

The results of analyses on fatigue crack propagation lives when it was not succeeded in completely refilling cracks by TIG arc remelting are given in Fig. 14 along with results of experiments. The stress range was considered to be 280 Mpa. The abscissa of the figure shows the depth of a crack before retrofitting. The results of experiments with SB specimens are also given in the figure. The analysis results indicate that fatigue life is shortened as crack depth before retrofitting become greater, while when crack

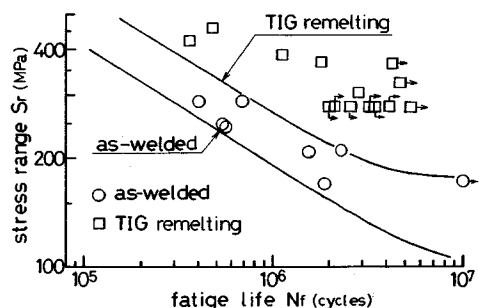

Fig. 13 Predicted S_r-N_f Relationships and Test Results.

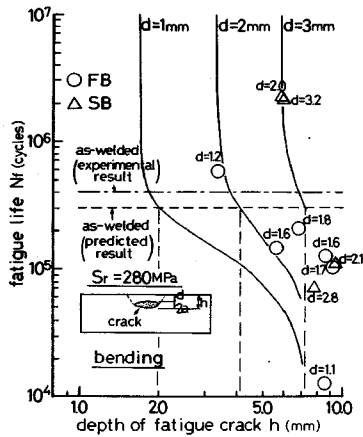

Fig. 14 Predicted Fatigue Life of Joints with Remaining Crack (under Bending).

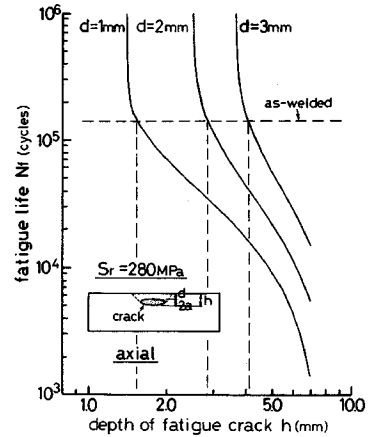

Fig. 15 Predicted Fatigue Life of Joints with Remaining Crack (under Axial Force).

depths are identical, the fatigue life shows a trend of becoming shorter the thinner the fused layer produced by TIG arc remelting, and the trend of experimental results is expressed well. According to the figure, if the thickness (d) of the fused layer obtained by TIG arc remelting is about 2 mm and the crack depth (h) before retrofitting is about 4.2 mm, and even when the fused thickness is 1 mm, if the crack depth is up to about 2.0 mm, the fatigue life of the retrofitted joint is equal to or longer than that of the as-welded joint, and it can be seen that retrofitting of fatigue cracks by TIG arc remelting is effective even when it is not succeeded in completely fusing the cracks. It is considered that the reasons a fair amount of fatigue life is obtained even when cracks remain are that the surface portions of the cracks are fused by the remelting to change the magnitudes and distributions of stresses at cross sections having cracks and that surface cracks are changed into internal cracks.

Analyses of fatigue crack propagation lives when cracks had remained were also performed for cases of being subjected to axial loads. The results are shown in Fig. 15. In these cases also, even when cracks of depth 2.8 mm had been produced, if fused depth of 2 mm could be obtained through TIG arc remelting, the lives of the joints were equal to those of as welded joints, and therefore retrofitting by TIG arc remelting was effective. However, the crack depth in order to have equal life as an as-welded joint is shallower compared with cases of being subjected to bending loads if the thicknesses of the fused layers are the same.

6. Conclusion

The principal results obtained in this study are the following :

- (1) When fatigue cracks had been completely fused by TIG arc remelting, the fatigue strength after retrofitting will be much higher than that of an as-welded joint.
- (2) Even though it is not succeeded in completely fusing fatigue cracks by TIG arc remelting, a fair amount of fatigue life can be expected if the remaining cracks are small and the layers of remelted zone are thick. The effect of retrofitting in such case will be greater under bending than under axial loadings.
- (3) It is possible to fuse the fillet weld toes 3 to 4 mm in depth by TIG arc remelting in accordance with the conditions used in this study. However, in order to complete sufficient retrofitting for fatigue cracks, the coincidence of the location of the fatigue crack and maximum fusion of TIG remelting is necessary.

REFERENCES

- 1) Hanzawa, M., Yokota, H., Ishiguro, T., Takashima, H., Kado, S., Tanigaki, T. and Hashida, Y. : Improvement of Fatigue

- Strength in Welded High Tensile Strength Steels by Toe Treatment, IIW-Document XIII-829-77, 1977.
- 2) Miner, H.H. and Seeger, T. : Improvement of Fatigue Life of Welded Beams by TIG-Dressing, IABSE Coloquium Lausanne 1982, pp. 385~392, 1982.
 - 3) Harrison, J. D. and Hale, N. P. : A Summary of Techniques for Improving the Fatigue Strength of Welded Structures and an Estimate of their costs, The Welding Institute Contract Report C 215/12/69, 1969.
 - 4) Fisher, J. W. : Fatigue and Fracture in Steel Bridges, JOHN WILEY & SONS, pp. 42~60, 1984.
 - 5) Fisher, J. W., Bernard, B. M., Mertz, D. R. and Edinger, J. A. : Fatigue Behavior of Full-Scale Welded Bridge Attachments, Lehigh University, Fritz Engineering Laboratory Report No. 446-1, 1980.
 - 6) Maddox, S. J. : An Analysis of Fatigue Cracks in Fillet Welded Joints, International Journal of Fracture, Vol. 11, No. 2, pp. 221~243, 1975.
 - 7) Albrecht, P. and Yamada, K. : Rapid Calculation of Stress Intensity Factors, Proceedings of ASCE, Vol. 103, No. ST 2, pp. 377~389, 1977.
 - 8) Newman, J. C. Jr : A Review and Assesment of the Stress Intensity Factors for Surface Cracks, ASTM STP 687, pp. 16~42, 1979.
 - 9) Okamura, H. : Introduction to Linear Elastic Frature Mechanics, Buifukan, 1976 (in Japanese).
 - 10) Okumura, T., Nishimura, T., Miki, C. and Hasegawa, K. : Fatigue Crack Growth Rates in Structural Steel, Proceedings of JSCE, No. 322, pp. 175~178, 1982.
 - 11) Miki, C., Mori, T. and Tajima, J. : Effect of Stress Ratio and Tensile Residual Stress on Near Threshold Fatigue Crack Growth, Proceedings of JSCE, No. 368, pp. 187~193, 1986.
 - 12) Miki, C., Mori, T., Sakamoto, K. and Sasaki, T. : The Evaluation of Fatigue Crack Growth from Blowholes at the Root of Longitudinal Groove Welds, Journal of Structural Engineering, Vol. 32 A, pp. 11~23, 1986 (in Japanese).
 - 13) Miki, C., Mori, T., Sasaki, T., Takena, K. and Sakamoto, K. : Fatigue Strength of Longitudinal Fillet Welded Joints (Influence of Weld Stop and Start Operations), Quarterly Journal of the Japan Welding Society, Vol. 4, No. 2, pp. 157~164, 1986 (in Japanese).

(Received JULY 4 1986)