

FATIGUE CRACKING OF FILLET WELDING JOINT ON ATTACHMENT UNDER COMPRESSIVE CYCLIC STRESSES

By Tohru NATORI, Makoto FUKAZAWA* and Hiromasa TERADA**

The previous study on the fatigue behavior of the truss chord member revealed fatigue cracking in fillet weld at the bed plate, which was attached to the compression flange plate. Therefore, bending fatigue tests were carried out using box-section specimens, with various types of attachments welded to the compression flange. In this paper, fatigue cracking phenomenon and fracture characteristics of transverse fillet weld under compressive cyclic stresses are described. Also, the influence of the length of attachment, weld size and the effect of surface grinding are investigated.

Keywords: bridge fatigue test attachment compressive stress residual stress

1. INTRODUCTION

At any welded joint, there generally exists a tensile welding residual stress, which may be equal to the yield point of the weld metal. According to recent studies, it has been reported that the mean stress has little effect on the fatigue strength of the welded joints in which the high tensile residual stress exists, but the cyclic stress range does affect the fatigue strength¹⁾. Even a welded joint, which is subject to compressive cyclic stress only, will in fact undergo tensile cyclic stresses because of the existence of high tensile residual stress, and fatigue cracks will therefore develop. Through the bending fatigue tests on box section specimens by the authors, it had been observed that many fatigue cracks developed from the blowholes at the roots of the corner welded joint in the compression side and the fatigue life was more or less the same as that of the tension side²⁾.

Generally, various attachments such as rib plates, gusset plates, cover plates, bed plates, are welded to structurel members of the bridge. For the attachment welded to the tension member, the fatigue behaviour has already been studied well^{3)~7)}. With regard to the fatigue cracking of these welded joints under compressive cyclic stress, however, no investigations have been carried out. And also in the design and fabrication of bridges, little attention is paid to the fatigue cracking of compression members, as compared to tension members.

One of the authors had performed a full-scale fatigue test on the transverse chord member of a stiffening truss in a cable-stayed bridge, designed for combined highway and railway⁸⁾. During this test, a number of fatigue cracks were observed at the root of the transverse fillet weld, connecting the bed plate of the inspection sidewalk with the compression flange. Also at the bending fatigue test of the main truss chord, various cracks were detected in the loading plate which had been attached to the compression flange by a

* Member of JACE, Research Institute, Yokogawa Bridge Works, LTD. (88 Shinminato, Chiba-Shi, Chiba, 260)

fillet weld⁹⁾. As for the latter case, though it has the particular stress condition, as a loading point, it is suggestive that, even under compressive cyclic stress, fatigue cracking will occur. As it is expected that bridges will be larger and more complicated, the possibility of such fatigue cracking in compression members will be much greater.

For this reason, this study was made to examine the initiation and propagation behavior of fatigue cracks at the fillet weld joints of attachments under compressive cyclic stress. In addition, the effect of grinding of the toe of fillet weld and the influence of the fillet weld size and the length of the attachment on fatigue cracking were examined.

2. SPECIMEN AND OUTLINE OF TEST

Fig. 1 shows the configuration and dimension of the specimen and the loading method. A four-point bending fatigue test was carried out on a box section specimen of 200 mm (*W*) × 230 mm (*H*), made of 15 mm thick plate, with 5 m span and 2 m spacing between loading points. Four specimens were fabricated, and a total of 32 attachments were welded to the compression flange, maintaining sufficient distance between them, in order to avoid possible effects from each other. The attachments were roughly classified into two series, In A-series the toes of the fillet welds were kept as welded, and in B-series the toes were finished by grinder. Fig. 2 shows the configuration and dimension of the attachments, each of them having a uniform width of 80 mm and thickness of 9 mm.

The length (*L*) of the A-series attachments was set at 100 mm, and the size of the fillet weld (*S*) was 6 mm of the standard size which is specified in Specifications for Steel Railway Bridges, $S = \sqrt{2l}$.

For B-series, the length of the attachment and the size of the fillet weld were changed to *L* = 25, 50, 100 and 150 mm and *S* = 4, 6, and 8 mm, for the purpose to examine the effect on the initiation of fatigue cracks.

The steel materials used for the testing were 600 MPa class quenched and tempered steel for box section

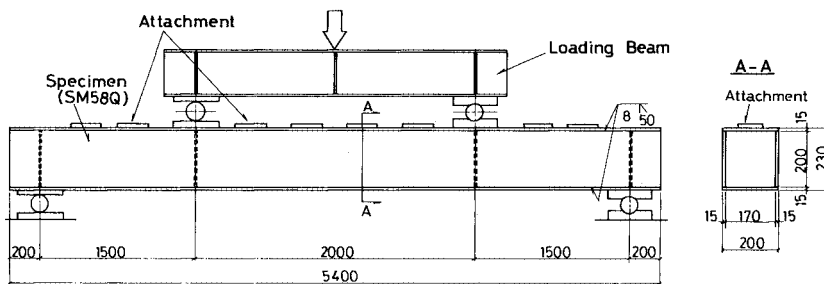

Fig. 1 Configuration and Dimension of Specimen.

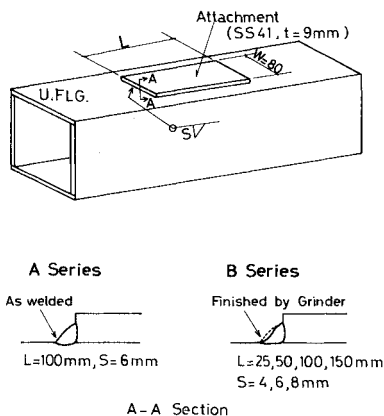

Fig. 2 Dimension of Attachment and Welding Details.

Table 1 Chemical Composition and Mechanical Property of Steel.

		Chemical Composition %						Mechanical Properties			
		C	Si	Mn	P	S	Cu	Mo	Yield Strength MPa	Tensile Strength MPa	Elongation %
Specimen	SM58Q t=15	0.13	0.23	1.38	0.011	0.003	-	-	550	650	38
Attachment	SS41 t=9	0.12	0.22	1.03	0.017	0.010	-	-	310	440	31

and 400 MPa class mild steel for the attachments. The chemical compositions and mechanical properties of steels are shown in Table 1. The fillet welding of the attachments was done using 500 MPa class low hydrogen type electrodes.

3. FATIGUE TEST

The fatigue test was carried out using a testing machine with a dynamic capacity of 200 N. The cyclic loading wave form was sinusoidal, with a frequency of 5 Hz. Three different testing stress ranges were used with reference to the allowable stress range in the fatigue design code⁽⁰⁾. Fig. 3 shows the stress conditions in the constant moment region. The stress ranges at the top of the compression flange plate were 102 MPa, 113 MPa and 134 MPa. Considering the additional coefficient of 30 % above the allowable stress range in the compression stress condition as specified in the fatigue design code⁽⁰⁾, the stress range of 102 MPa becomes equivalent to Category D, and 134 MPa to Category C.

In the variable moment region, the stress ranges at the attachment edge, on the side of greater stress, were 80 MPa and 102 MPa at the top of the flange plate. In the fatigue design code, the classification of the fillet weld joints for the attachments, which are the objects of interest here, is not clear. If it is considered equivalent to the transverse fillet welded joint at the end of a cover plate, Category C could be applied when the end is finished by grinder, Category D when the end is as-welded.

In the fatigue test, 200 000 cycles of the halved stress range were inserted every 500 000 cycles, to leave beachmarks on the fatigue crack surfaces.

4. RESULTS OF FATIGUE TESTS

(1) Summary of Test Results

The initiation of fatigue cracks was observed in the fillet welds of the attachments on every specimen. Observing the crack growth, the fatigue tests were continued to 3 000 000 cycles.

After the fatigue testing, confirmation of the surface cracks was carried out using a magnetic particle tester. In addition, the fillet welds were destroyed along the weld root to establish whether some concealed fatigue cracks had existed in it. The cracks were then exposed, and beachmarks were examined. The results of the investigation of the crack occurrence are shown in Table 2.

As for A-series attachments, where the fillet weld was as-welded, fatigue cracks initiated at the toe of the fillet weld. On the other hand, in B-series, where grinder finishing was performed on the toe, all the cracks were formed in the root of the fillet weld. In the Table 2, the crack width '2 b' and the crack depth 'a'

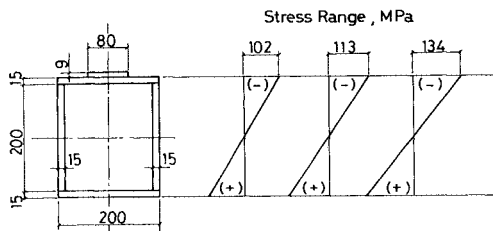

Fig. 3 Stress Range in Constant Moment Region.

Table 2 Fatigue Test Results.

Specimen		Fatigue Test Results						Remarks	
Series	No.	Attachment size		Sr	Location of crack initiation	Crack size			Type of crack
		L, mm	S, mm	MPa		a, mm	2b, mm		
A - Series As welded	A 1			78	No cracked			Type (i) Toe	
	A 1'			78	"				
	A 2	100	6	102	"				
	A 3			102	Toe	15.0	135.8		
B - Series Finishing by Grinder	A 3'			113	Toe	13.5	121.2	Type (i) Root	
	A 4			113	Toe	14.7	128.4		
	A 3			134	Toe	14.6	127.6		
	A 4			134	Toe	14.6	127.6		
	B 1			78	No cracked			Type (i) Root	
	B 2			102	Root	4.2	79.1		
	B 3	100	6	102	Root	14.4	129.7		
	B 4			113	Root	15.0	125.5		
	BL-25-1	25	6	113	No cracked			Type (i) Root	
	BL-25-2			134	"				
	BL-50-1			102	No cracked				
	BL-50-2	50	6	113	"				
BS ⁰ 4 - 1	1			134	"			Type (ii) Root	
	2			78	No cracked				
	3			102	Root	5.8	59.1		
	3			102	Root				
	BS ⁰ 4 - 2	150	6	102	Root	5.5	65.1	Type (ii) Root	
	2			102	Root	3.7	41.9		
	3			102	Root	13.8	123.3		
	3			113	Root				
	BS ⁰ 4 - 3	1			78	No cracked			Type (ii) Root
		2	100	4	102	Root	3.7	82.5	
		3			102	Root	14.2	125.6	
		3			113	Root	15.0	131.2	
BS-8-1	2	100	8	102	No cracked			Type (i) Root	
	2			113	"				
	3			134	Root	2.4	33.2		

* : Varying attachment length
* * : Varying weld size

for each crack are shown. The cracks originating at the root are classified into 3 different types, in accordance with the crack growth as shown in Table 2.

(2) As-Welded Transverse Fillet Joints (A-series)

In the case of the 'as-welded' A-series fillet welds, every cracks started from the weld toe. Fig. 4 shows the state of cracks, and Fig. 5 is the appearance of typical crack. It shows that the fatigue cracks propagate along the weld toe, and after they spread over the full width of the attachment ($W=80$ mm), they propagate to the flange plate. It is discovered that, even under compressive stress conditions, the cracks propagate into quite broad areas, in the case that the stress range is over 100 MPa. Fig. 6 shows the fracture surface of the typical crack. At the toe of the weld, multiple minute cracks initiate along the weld line, and each crack joins together and develops into a large semielliptical crack. After 2 000 000 cycles, there is no particular change in the beachmark dimensions, and the growth rates of the cracks are going slow down. However, after the testing ($N=3\ 000\ 000$ cycles), it is shown that the cracks have propagated through up to 90 % of flange thickness, and the compression flange reduces in cross section. The fatigue strength differs as to how the fatigue life is defined. Should the fatigue strength be evaluated by the existence of cracks, it would be around 102 MPa. This magnitude corresponds to the allowable stress range of Category D at the compressive cyclic stress condition. Therefore, from the point of view of preventing the occurrence of fatigue cracks, fillet weld of attachments should be designed as the joint of Category lower than Category D.

(3) Transverse Fillet Weld with Toe Finishing (B-series)

Cracks in the B-series attachments, where the weld toes were finished by grinder, initiated from the

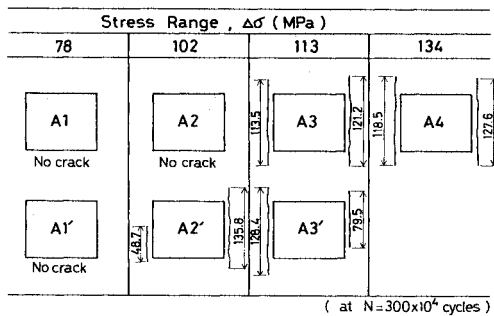

Fig. 4 Fatigue Cracks Originated along Weld Toe.

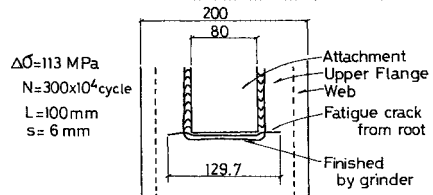
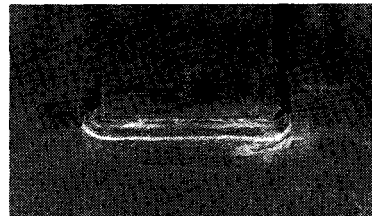

Fig. 5 Appearance of Typical Crack (A2).

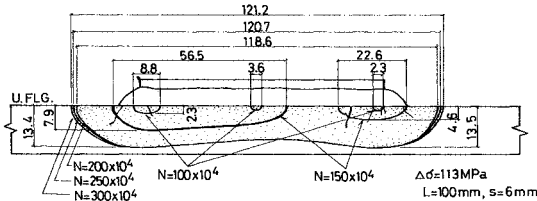
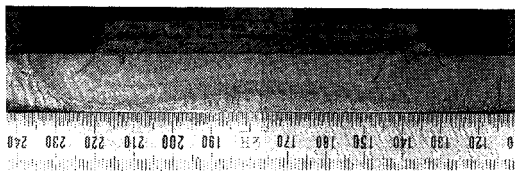

Fig. 6 Fracture Surface of Toe Crack (A3).

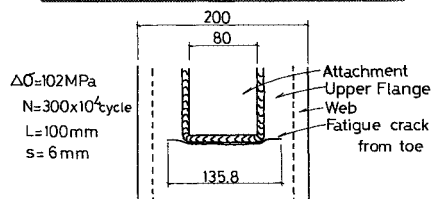
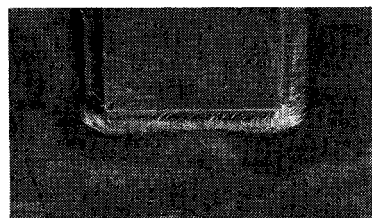

Fig. 7 Appearance of Typical Crack (B3).

root of the fillet weld. Fig. 7 shows the typical appearance of the root fatigue crack. After penetration through the throat of the fillet weld, they advance into the flange plate, as same as the case of toe cracks. Fig. 8 shows the results of measurements performed on the profile of the weld toe. It shows that by grinding of the toe, radius ρ and flank angle θ became greater than A-series. Therefore the stress concentration is reduced at weld toe, and the fatigue cracks do not initiate from the weld toe, even though the stress range is 134 MPa. However, as can be seen in Table 2, the cracks in the root are also initiated at 102 MPa. This may suggest that between the root crack and the toe crack, there is no difference of the stress range at which the cracks initiate.

Fig. 9 shows the fracture surface of a typical crack.

At the early stage of cyclic loading, it is confirmed that multiple cracks are advancing toward the weld throat (type i). These cracks penetrate through the weld throat while spreading and becoming wide and flat (type ii). After the cracks become larger than the width of the attachment, they advance further into the flange plate (type iii).

Almost at the same time, another cracks initiate from the weld root, while propagating into the flange plate. This crack exists in the different section to those which have been propagating from the transverse fillet weld. These two cracks have been penetrating into the flange plate, independently. This cracking also shows a tendency to slow down as its size increased, too.

(4) Effects of Attachment Length and Fillet Weld Size (BL, BS Series)

Fig. 10 and 11 show the relation between the applied stress range and attachment length (L), fillet weld size (S). The solid curves in these show the limit for the crack initiation. It is apparent from these figures that the shorter the attachment length and the greater the fillet weld size, the greater the limit of the

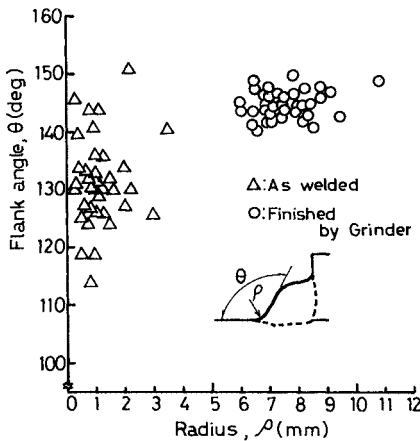

Fig. 8 Flank Angle and Radius at Weld Toe.

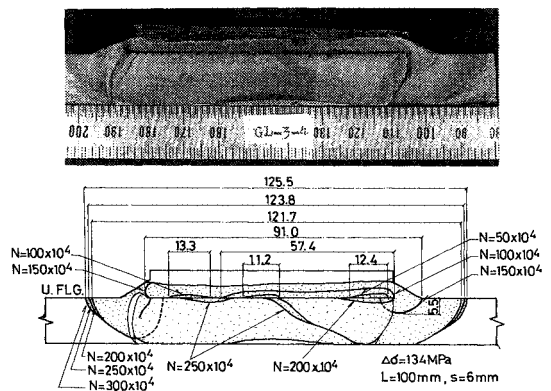

Fig. 9 Fracture Surface of Root Crack (B44).

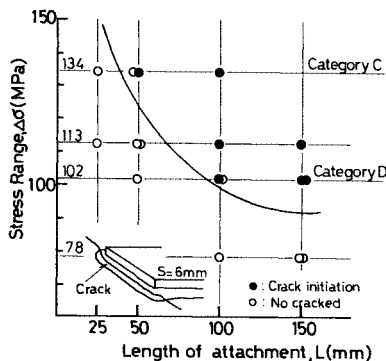

Fig. 10 Influence of Attachment Length.

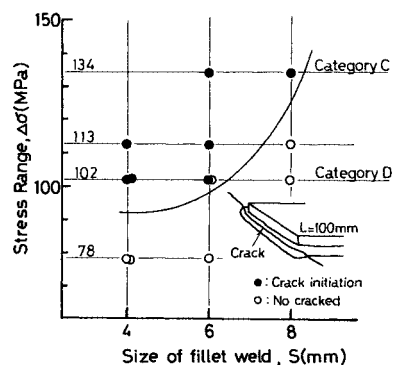

Fig. 11 Influence of Fillet Weld Size.

stress range for the crack initiation.

Fig.12 shows the axial strain distribution measured on the center section of the attachment. This suggests that, when the size of fillet weld is increased, the strain of the attachment also slightly increase. But the strain increment is smaller than that of the fillet weld size, and the mean stress of the throat section in the fillet weld is lowered. It may be considered that the limit stress range for crack initiation is increased in the case of large weld size. In the previous study⁸⁾, a series of finite element analysis were carried out on similar joints with various fillet weld sizes. As the result of such analysis, it had been found that when the fillet weld size increased to two times, the axial force run through the attachment increased by 22 %, but the local maximum principal stress at the weld-root decreased to 88 %. It seems that the outcome of this current experiment shows a similar tendency and agrees with the analytical results.

With regard to the attachment length, it is obvious that longer the attachment length, the greater the strain in it. This may be because that the axial force transitting fillet weld is increasing. If the size of fillet weld remains the same, stress at the root would be greater, and then the fatigue strength would be reduced.

Fig. 14 shows the results of the finite element analysis performed on the attachment length , using the models as shown in Fig. 13. The analysis reveals that the longer the attachment, the greater the load sharing ratio of attachment, and also the greater the local stress at the root, as have been shown in this experiment.

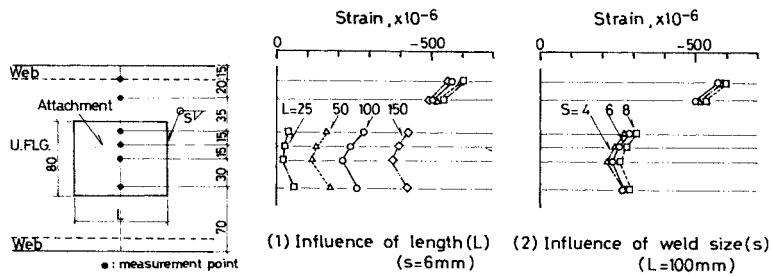

Fig. 12 Strain Distribution on Attachment.

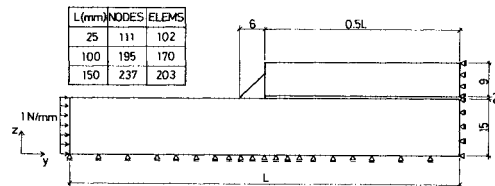

Fig. 13 Model of Finite Element Method.

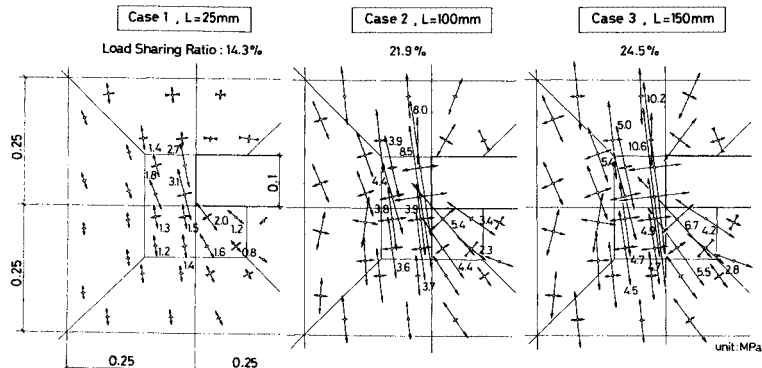

Fig. 14 Principal Stress Diagram.

From these results, it could be said that to improve the fatigue strength of the fillet weld of the attachment, it is not sufficient only to finish the weld toe, but essential to reduce the stress acting at the weld root. It is effective to shorten the length of the attachment and to enlarge the fillet weld size, from the point of view of preventing fatigue cracking from the root of the fillet weld.

(5) Retardation of Fatigue Crack Propagation

Fig. 15 shows the relationship between dimensions of crack and the number of stress cycles. Every cracks show the retardation of its propagation, after having developed to a certain size. For the cracks initiated at the weld root, similar phenomena have been seen, after the cracks have penetrated into the flange plate. This is recognized by the observations of the beachmarks on the fracture surface.

These retardation phenomena are considered to be that there is a close relation with the relief of the tensile residual stresses by the crack growth. From this point of view, an examination was performed on the redistribution of the residual stress, by means of measuring of strain change, when the fatigue cracks were propagating. Fig. 16 shows the measuring locations of strains. Before the fatigue test was carried out, strain gauges (G. L. =5 mm) were attached at locations appoximately 3 mm away from the toes of the transverse fillet welds. The strains were then measured every 500 000 cycles under an unloading condition. Fig. 17 shows there distribution of the residual stress, when the cracks are propagating at the weld toes. The profiles of the cracks in Fig. 17 indicate the bechmarks at the every number of the stress cycles. In the initial state, tensile residual stresses ranging from 200 MPa to 280 MPa are introduced along the front fillet weld, and residual stresses at the end of the front fillet weld is slightly higher than that at the center of the fillet weld. Also, the tensile stress at the corner weld of the box section is about 400 MPa, and a certain compressive residual stress zone exists in the flange plate between the corner weld and the attachment.

When fatigue crack initiates in the fillet weld, the residual stresses near crack are relieved and reduced ($N=150 \times 10^4$). Because the number of measurements performed is few as every 500 000 cycles, and the positions in which the strain gauges are 3 mm apart from the position of the fatigue crack, it is impossible to gain complete informations as to how the residual stress changes at the tip of a fatigue crack. But it is seen that the residual stress near the tip of the crack shows a tendency to increase, as the cracks propagate. It is also discovered that the crack would most likely be stagnant in the region where compressive residual stresses exist originally. It is considered, however, that in the region of initial compressive stress, the residual stress is a little redistributed and the compressive stress reduces by propagation of the cracks. But it would not be sufficient to produce the tensile residual stress necessary to further propagate the crack. It is considered that therefore the fatigue cracks has retarded. As for the fillet weld root, measurements of the residual stress distribution were also carried out. It was recognized that after the cracks had propagated into the flange plate, the behavior of the stress change was exactly same as the above. One may also consider the possibility of a redistribution of the residual stress due to the local yielding under some imposed load⁽¹⁾. But it was found that there was no notable difference between the

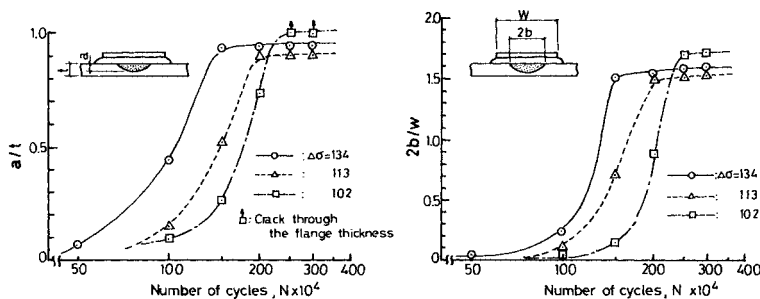

Fig. 15 Fatigue Crack Propagation from Weld Toe.

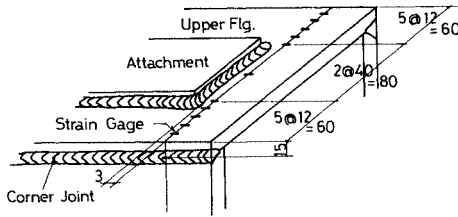

Fig. 16 Location of Strain Gages.

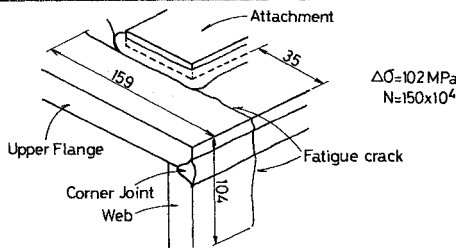
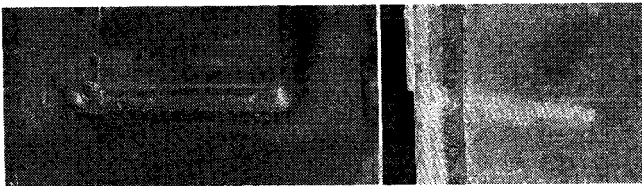

Fig. 18 Fatigue Crack Propagating into Web Plate.

value of the initial strains at time of no loading, and the value of the strains after 100 000 loading cycles. Therefore, the effect of a loading is not recognized at all.

As mentioned above, the propagation of cracks developed in compression members is considered to be affected greatly by the region of tensile residual stress. Fig. 18 shows the crack propagation in the case that the attachment is welded near the corner weld of a box section, as further study. In this case, the residual stresses caused by the attachment welding are superposed on the other residual stresses produced by the corner welding. As a result, a considerable tensile residual stress region is formed, resulting in great crack development, and propagating into the web plate of the box section. For such large cracks, therefore, an investigation from the point of view of the ultimate strength of the members is necessary, and when designing joints to be used in region where other weld is in a close proximity, it is necessary to provide a full investigation, as to their safety against the fatigue cracking, even in compression members.

(6) Secondary Stresses due to Development of Cracks

Other root crack was observed at the corner weld joint of box section near the large fatigue crack in the flange plate, as shown in Fig. 19. It is considered that the occurrence of such a crack is due to the repetition of the secondary shear stress, owing to the disturbance of the stress flow in the flange plate. This suggests that an evaluation against the fatigue strength of the member in which fatigue cracks develop should be

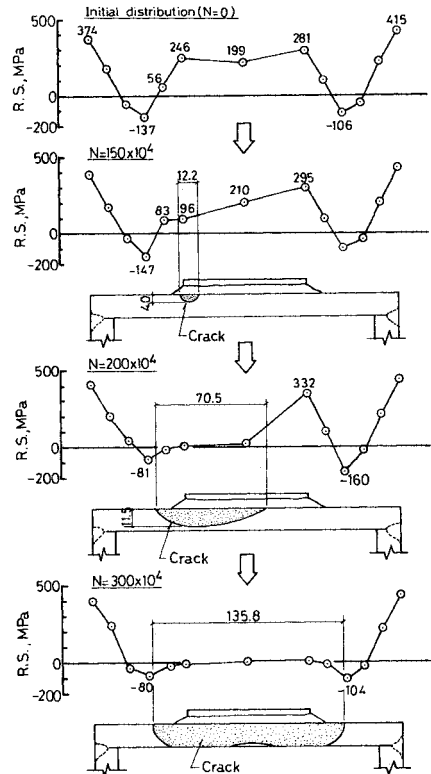

Fig. 17 Change of Residual Stress Distribution with Crack Propagation (A2).

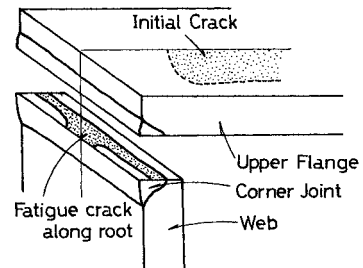
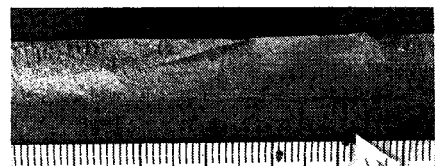

Fig. 19 Fatigue Crack along Root of Corner Weld.

included the possible effects on other welded joints, as well.

5. CONCLUSION

In order to investigate the fatigue cracking in the fillet weld on attachments welded to compression members, a series of bending fatigue tests were carried out using a box section specimen. The results of this study are summarized as follows.

(1) Fatigue cracks occur even though the actual stress is compressive. When the toe of fillet weld has been as-welded, fatigue cracks initiate from the weld toe and propagate to the flange plate, forming a crack of semi-elliptical shape. In the attachment used in this experiment ($L=100$ mm, Size of Weld= 6 mm), the limit stress range against the crack initiation is about 100 MPa.

(2) It is possible to prevent the initiation of the cracks from the weld toe by finishing of the toe profile, but the crack will initiate from the root of the transverse fillet weld joint, too. This crack will propagate into the main plate, after penetrating through the throat of the fillet weld. The limit stress range against the initiation of cracks does not show any significant difference compared to that of the unfinished case. In order to improve in the fatigue strength by finishing by grinder, it is necessary to pay a close attention to the stress condition in the weld root.

(3) Crack initiation from the weld root is affected by both the attachment length and the fillet weld size. When the attachment length is shortened, and the fillet weld size is enlarged, the limit stress range against crack initiation seems to be increased. For both cases, this is due to the fact that the local stress at the root has become smaller.

(4) The cracks initiated under compressive cyclic stress are retarded in their propagation rate, by gradual relief of the tensile residual stress. However in the case that other weld exists in the vicinity, there is the extensive tensile residual stress region, and fatigue cracks largely develop even in compressive members. Therefore, it is suggested that particular attention should be paid to the fatigue cracking in these cases.

REFERENCES

- 1) Hirt, M.A., Yen, B.T. and Fisher, J.W. : Fatigue Strength of Rolled and Welded Steel Beams, *Journal of Structural Division, Proc. of ASCE*, ST7, 1971.
- 2) Fukazawa, M., Natori, T., Terada, H. and Akashi, S. : Effect of Stress Relief on Fatigue of High Strength Steel Corner Joint with Blowhole, *Proc. of JSCE Structural Eng./Earthquake Eng.* Vol.2, No.1, 1985.
- 3) Tagaki, N., Kondo, A., Yamada, K. and Kikuchi, Y. : Effect of Welded Profiles on Fatigue Strength of Fillet Welding Specimens, *Proc. of JSCE*, No.324, 1982 (in Japanese).
- 4) Yamada, K., Sakai, Y. and Kikuchi, Y. : Fatigue of Tensile Plate with Gussets and Stop Holes as Crack Arrest, *Proc. of JSCE*, No.341, 1984 (in Japanese).
- 5) Shimokawa, H., Tanaka, K., Ito, F. and Miki, C. : *Earthquake Eng.*, Vol.1, No.1, 1985.
- 6) Iida, K., Miyasako, K., Ohgi, M. and Okano, Y. : An Investigation of Influencing Factors on Bending Fatigue Strength of Fillet Welded Joint, *Journal of SNAJ*, Vol.143, 1978 (in Japanese).
- 7) Ohta, S. and Kudo, S. : Improving the Fatigue Strength of Fillet Welded Joints by Grinding and Wire Peening (Report 1), *Journal of JWS*, Vol.49, No.2, 1980 (in Japanese).
- 8) Sakamoto, K., Yasuda, M., Fukazawa, M. and Miki, C. : An Investigation on Fatigue Strength for Transverse chord of Stiffening Truss, *Proc. of JSCE Structural Eng./Earthquake Eng.*, Vol.1, No.2, 1985.
- 9) Shimokawa, H., Takena, K., Fukazawa, M. and Miki, C. : A Fatigue Test of The Full-Size Truss Chord, *Proc. of JSCE Structural Eng./Earthquake Eng.*, Vol.1, No.2, 1985.
- 10) Japan Society of Civil Engineers : Specification of Steel Railway Bridge, 1983 (in Japanese).
- 11) Nishino, T., Tajima, J., Okugawa, A. and Miki, C. : Fatigue Strength of Longitudinal Single-Bebel-Groove welded Member, *Proc. of JSCE*, No.291, 1979 (in Japanese).

(Received February 4 1986)