

TORSIONAL OSCILLATION ANALYSIS OF SUSPENSION BRIDGES BY A DISPLACEMENT METHOD

By *Yūichirō HAYASHI** and *Masanobu MURATA***

1. INTRODUCTION

Since the disaster of the Tacoma Narrow's Bridge in 1940, the dynamic analysis of suspension bridges has become of great importance and a lot of investigations have been made. Most of the analytical solutions concerned have relied upon the Rayleigh-Ritz^{1),2)} method—the energy method—or the differential equation method on the basis of both Melan's equation and the cable equation. However, it is difficult to apply those methods to suspension bridges with arbitrary structural configurations, both in completed and during erection stages.

The oscillation analysis for a suspension bridge can be formulated by a displacement method considering the structure as a set of discrete members. The method presented by Tezcan³⁾ is applicable to the dynamic problem, and Shiraki⁷⁾ has done oscillation analysis utilizing this method. The shortcoming of this method is the difficulty in the treatment of a stiffening truss with torsional rigidity.

Komatsu and Nishimura^{9),10)} analyzed the oscillation of a completed suspension bridge by Galerkin's method considering the cross sectional distortion of truss. They showed that the torsional frequencies of a long span, truss-stiffened suspension bridge were not affected by the sectional distortion of truss if the cross sectional distortion rigidity was larger than 10^5 (ton m/m). However, other effects such as the influence of a center-stay and the inclination of hangers were not dealt with in their work.

In this paper, a stiffness equation for a stiffening truss is derived from the basic torsional equations by Vlasov⁵⁾, by making use of the fact that

an ordinary cross section of a long span suspension bridge is regarded as rigid, while cables and hangers are presumed as a set of bars subjected to axial forces¹⁴⁾. Then, a procedure of torsional oscillation analysis in suspension bridges by a displacement method is presented utilizing the above-mentioned stiffness equations. According to the present method, the torsional analyses of suspension bridges with arbitrary configurations are easily made. For example, we can analyze suspension bridges with two-hinged or continuous type of stiffening truss, center-stay, center-tie, tower-stays, diagonal hangers, etc., either in the completed or erection stages.

2. STIFFNESS EQUATION FOR STIFFENING TRUSS

If a stiffening truss of a suspension bridge is replaced by a rectangular box girder, the following assumptions can be made;

Assumption 1: The cross section of the stiffening truss is biaxially symmetric.

Assumption 2: The cross section of the stiffening truss is rigid.

Assumption 1 means that torsional equations of the stiffening truss can be separated from bending equations of the stiffening truss. Assumption 2 is introduced to simplify the problem. Komatsu and Nishimura referred to effects of sectional distortion rigidity of the truss on torsional frequencies of a long span, truss-stiffened suspension bridge. They showed that period errors in the first symmetric and asymmetric modes were less than 1%, but those in higher modes became larger than 1% in the case that sectional rigidity was about 10^5 and 10^6 (ton m/m).

In this paper, we presumed that the cross section is rigid, because influential modes in wind resistant design are the first symmetric and asymmetric modes, and ordinary sectional distortion

* M. Eng., Civil Engineer, Third Construction Bureau, Honshu-Shikoku Bridge Authority.

** M. Eng., Civil Engineer, Planning Division, Honshu-Shikoku Bridge Authority.

rigidity is larger than 10^6 (ton m/m). So if the effects of cross sectional distortion are not neglected, the stiffness equation presented in references 10) and 13) should be used.

In the first place, the plane lattice system is replaced by an equivalent thin plate to cause the same shear deformations. The equivalent plate thickness for two typical frames is seen in Table 1. Those chord members are regarded as stiffeners at the four corners of the box girder as shown in Fig. 1.

Table 1 Equivalent Plate Thickness.

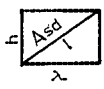
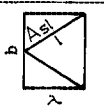
	$t = \frac{E_s}{G_s} \cdot \frac{h\lambda A_{sd}}{l^3}$
	$t = \frac{E_s}{G_s} \cdot \frac{b\lambda A_{st}}{2l^3}$

Note: The effect of vertical members has been neglected.

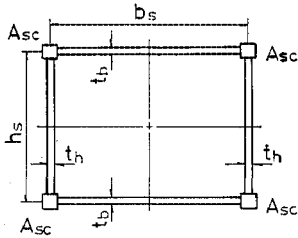

Fig. 1 Idealized Model Section of Stiffening Truss.

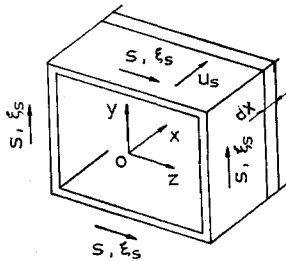

Fig. 2 Co-ordinates.

If each plate element cut into a width of dx has a degree of freedom as a rigid body, the displacements u_s and s shown in Fig. 2 are expressed as follows;

$$u_s = \sum_{i=1}^4 U_i A_i \dots\dots\dots(1)$$

$$s = \sum_{i=0}^4 S_i B_i \dots\dots\dots(2)$$

where

$U_i = U_i(x)$ ($i=1\sim 4$): Generalized out-of-plane displacements

$S_i = S_i(x)$ ($i=1\sim 4$): Generalized in-plane displacements

$A_i = A_i(\xi_s)$ ($i=1\sim 4$): Out-of-plane displacement modes

$B_i = B_i(\xi_s)$ ($i=1\sim 4$): In-plane displacement modes

According to assumption 1, torsional equations are separated from the other equations. In the absence of distributed external loads, the torsional equations are

$$a_w U'' - b_1 U + b_2 \phi' - b_1 \theta' = 0 \dots\dots\dots(3)$$

$$b_2 U' - b_1 \phi'' + b_2 \theta'' = 0 \dots\dots\dots(4)$$

$$b_1 U' - b_2 \phi'' + b_1 \theta'' - \gamma \theta = 0 \dots\dots\dots(5)$$

where

U : Generalized warping corresponding to mode A_1

ϕ : Rotation angle corresponding to mode B_1

θ : Generalized cross sectional distortion angle corresponding to mode B_2

$$a_w = E_s A_{s0} \frac{b_s^2 h_s^2}{4}$$

$$b_1 = G_s (t_h b_s + t_b h_s) \frac{b_s h_s}{2}$$

$$b_2 = G_s (t_h b_s - t_b h_s) \frac{b_s h_s}{2}$$

γ : Generalized stiffness of cross sectional distortion per unit length

E_s : Modulus of elasticity

G_s : Modulus of transverse elasticity

and the modes A_1 , B_1 and B_2 are as shown in Fig. 3.

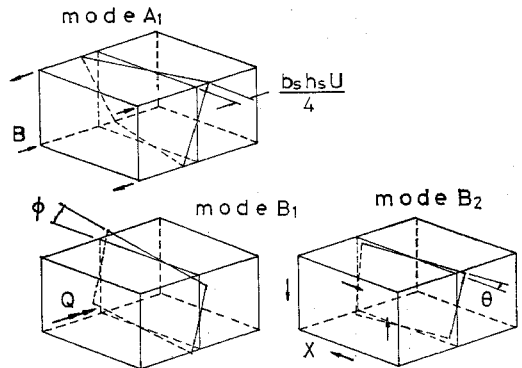

Fig. 3 Generalized Displacement Modes.

Let Q be a torsional moment, B be a bimoment, X be a cross sectional distortion moment, namely a transverse bimoment, then these generalized forces are given as

$$B = -a_w U' \dots\dots\dots(6)$$

$$Q = b_2 U - b_1 \phi' + b_2 \theta' \dots\dots\dots(7)$$

$$X = -b_1 U + b_2 \phi' - b_1 \theta' \dots\dots\dots(8)$$

If Eqs. (3) and (4) are expressed in the form of $f(x)$, the generalized displacements $U(x)$, $\phi(x)$ and $\theta(x)$ will be expressed as follows.

$$U = f' \dots\dots\dots(9)$$

$$\phi = \frac{a_w b_1}{\gamma b_2} f^{(4)} - \frac{a_w}{b_2} f^{(2)} + \frac{b_1}{b_2} f \dots\dots\dots(10)$$

$$\theta = \frac{a_w}{\gamma} f^{(4)} \dots\dots\dots(11)$$

Letting $\gamma \rightarrow \infty$ from assumption 2, $\theta = 0$ can be obtained from Eq. (11). Substituting Eqs. (9)~(11) into (4) and assuming $\gamma \rightarrow \infty$, Eq. (12) is obtained.

$$f^{(4)} - \frac{k_f^2}{l_f^2} f^{(2)} = 0 \dots\dots\dots(12)$$

where

$$k_f^2 = \frac{G_s J_s}{a_w} l_f^2$$

$$G_s J_s = \frac{b_1^2 - b_2^2}{b_1} : \text{St. Venant's torsional rigidity}$$

l_f : Distance between joints used in the stiffness equation.

When $\theta = 0$, the relation between Q , B , ϕ and U , from Eqs. (6), (7), (9) and (10), becomes

$$Q = -\frac{1}{b_2} \{ (b_1^2 - b_2^2) f' - a_w b_1 f^{(3)} \} \dots\dots\dots(13)$$

$$B = -a_w f^{(2)} \dots\dots\dots(14)$$

$$\phi = \frac{1}{b_2} (b_1 f - a_w f^{(2)}) \dots\dots\dots(15)$$

$$U = f' \dots\dots\dots(16)$$

The general solution of Eq. (12) is as follows.

$$f = C_1 \sinh \frac{k_f}{l_f} x + C_2 \cosh \frac{k_f}{l_f} x + C_3 x + C_4 \dots\dots\dots(17)$$

The following stiffness equation for the girder is obtained from Eqs. (13)~(17) and the boundary conditions as shown in Fig. 4.

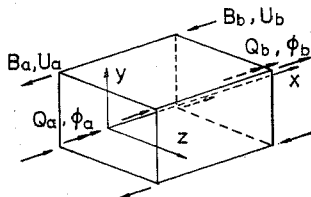

Fig. 4 Boundary Conditions.

$$\{dF^s\} = [k^s] \{dx^s\} \dots\dots\dots(18)$$

where

$$\{dF^s\} = [B_a, Q_a, B_b, Q_b]^T$$

$$\{dx^s\} = [U_a, \phi_a, U_b, \phi_b]^T$$

$$[k^s] = \begin{bmatrix} k_{11} & & & \\ k_{21} & k_{22} & \text{sym.} & \\ k_{31} & k_{32} & k_{33} & \\ -k_{21} & -k_{22} & -k_{31} & k_{22} \end{bmatrix}$$

$$k_{11} = G_s J_s \frac{l_f}{k_f} \frac{k_f - (b_2/b_1)^2 \tanh k_f}{k_f \tanh k_f - 2(b_2/b_1)^2 (1 - \text{sech } k_f)}$$

$$k_{21} = G_s J_s \frac{b_2}{b_1} \frac{1 - \text{sech } k_f}{k_f \tanh k_f - 2(b_2/b_1)^2 (1 - \text{sech } k_f)}$$

$$k_{22} = \frac{G_s J_s}{l_f} \frac{k_f}{k_f - 2(b_2/b_1)^2 (\coth k_f - \text{cosech } k_f)}$$

$$k_{31} = \frac{G_s J_s l_f}{k_f} \frac{(b_2/b_1)^2 - k_f \text{cosech } k_f}{k_f - 2(b_2/b_1)^2 (\coth k_f - \text{cosech } k_f)}$$

3. ANALYSIS FOR FREE TORSIONAL OSCILLATIONS OF A SUSPENSION BRIDGE

In order to set up the equation of free torsional oscillations for a suspension bridge, the following assumptions are added;

Assumption 3: The amplitudes of oscillation are very small.

Assumption 4: The inertial masses of cables concentrate on the cable joints and the moments of inertia of the stiffening girder also concentrate on its joints.

Assumption 5: The longitudinal inertial masses corresponding to the generalized warping of the stiffening girder are neglected.

Assumption 6: The movements of cables on both sides toward the vertical and longitudinal directions are the same and in the opposite phase. Toward the out-of-plane, transverse direction, the movements of both cables are the same and in the same phase.

Prior to the oscillation analysis for the suspension bridge, hanger intervals should be properly widened in order to reduce the number of degrees of freedom. Thus a new equilibrium configuration and forces due to dead loads should be established by the finite deformation theory.

The displacements of the suspension bridge are defined as shown in Fig. 5. The following stiffness equations for both cables can be derived by using assumption 3 and reference 14). The notations in these equations are shown in Fig. 6.

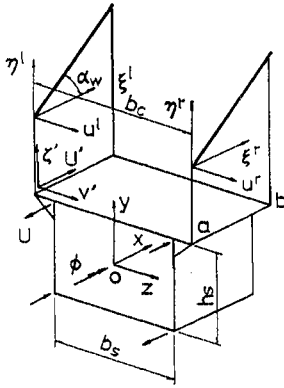

Fig. 5 Displacements of Suspension Bridge.

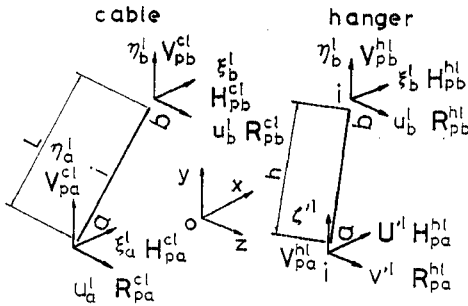

Fig. 6 Joint Forces and Displacements of Cable and Hanger.

$$\{dF^{cl}\} = [k^c] \{dx^{cl}\} \dots\dots\dots(19a)$$

$$\{dF^{cr}\} = [k^c] \{dx^{cr}\} \dots\dots\dots(19b)$$

where

$$\{dF^{cl}\} = [H_{pa}^{cl}, V_{pb}^{cl}, R_{pb}^{cl}, H_{pb}^{cl}, V_{pb}^{cl}, R_{pb}^{cl}]^T$$

$$\{dF^{cr}\} = [H_{pa}^{cr}, V_{pb}^{cr}, R_{pb}^{cr}, H_{pb}^{cr}, V_{pb}^{cr}, R_{pb}^{cr}]^T$$

$$= [-H_{pa}^{cl}, -V_{pb}^{cl}, R_{pb}^{cl}, -H_{pb}^{cl}, -V_{pb}^{cl}, R_{pb}^{cl}]^T$$

$$\{dx^{cl}\} = [\xi_a^i, \eta_a^i, u_a^i, \xi_b^i, \eta_b^i, u_b^i]^T$$

$$\{dx^{cr}\} = [\xi_a^i, \eta_a^i, u_a^i, \xi_b^i, \eta_b^i, u_b^i]^T$$

$$= [-\xi_a^i, -\eta_a^i, u_a^i, -\xi_b^i, -\eta_b^i, u_b^i]^T$$

$$[k^c] = \begin{bmatrix} [k^{cc}] & -[k^{cc}] \\ -[k^{cc}] & [k^{cc}] \end{bmatrix}$$

$$[k^{cc}] = \frac{A_c E_c}{L_0} [l_1^c] + \frac{T_w^c}{L} [l_2^c]$$

$$[l_1^c] = \begin{bmatrix} l^2 & \text{sym.} \\ lm & m^2 \\ ln & mn & n^2 \end{bmatrix}$$

$$[l_2^c] = \begin{bmatrix} 1-l^2 & \text{sym.} \\ -lm & 1-m^2 \\ -ln & -mn & 1-n^2 \end{bmatrix}$$

- A_c : Cross sectional area of one cable
- E_c : Modulus of elasticity of cable
- $L_0 (\approx L)$: Unstrained length of cable link
- L : Strained length of cable link
- l, m, n : Direction cosines of cable link
- T_w^c : Cable tension due to dead load

Thus, the stiffness equation of the hanger can be established. It is permitted that the hangers or stays are diagonally tightened. With reference to Fig. 6, the stiffness equation of the hanger becomes as follows,

$$\{dF^{hl}\} = [k^h] \{dx^{hl}\} \dots\dots\dots(20a)$$

$$\{dF^{hr}\} = [k^h] \{dx^{hr}\} \dots\dots\dots(20b)$$

where

$$\{dF^{hl}\} = [H_{pa}^{hl}, V_{pb}^{hl}, R_{pb}^{hl}, H_{pb}^{hl}, V_{pb}^{hl}, R_{pb}^{hl}]^T$$

$$\{dF^{hr}\} = [H_{pa}^{hr}, V_{pb}^{hr}, R_{pb}^{hr}, H_{pb}^{hr}, V_{pb}^{hr}, R_{pb}^{hr}]^T$$

$$= [-H_{pa}^{hl}, -V_{pb}^{hl}, R_{pb}^{hl}, -H_{pb}^{hl}, -V_{pb}^{hl}, R_{pb}^{hl}]^T$$

$$\{dx^{hl}\} = [U^i, \zeta^i, v^i, \xi^i, \eta^i, u^i]^T$$

$$\{dx^{hr}\} = [U^i, \zeta^i, v^i, \xi^i, \eta^i, u^i]^T$$

$$= [-U^i, -\zeta^i, v^i, -\xi^i, -\eta^i, u^i]^T$$

$$[k^h] = \begin{bmatrix} [k^{hh}] & -[k^{hh}] \\ -[k^{hh}] & [k^{hh}] \end{bmatrix}$$

$$[k^{hh}] = \frac{A_h E_h}{h_0} [l_1^h] + \frac{T_w^h}{h} [l_2^h]$$

$[l_1^h] = [l_1^c]$, $[l_2^h] = [l_2^c]$ in Eq. (19), but direction cosines are for a hanger

- A_h : Cross sectional area of a hanger
- E_h : Modulus of elasticity of hanger
- $h_0 (\approx h)$: Unstrained length of a hanger
- h : Strained length of a hanger
- T_w^h : Hanger tension due to dead load

The eight displacements, $\xi^i, \eta^i, u^i, U^i, \zeta^i, v^i, U$ and ϕ appear in one section of the suspension bridge, but five of those displacements remain independent because the following relations are derived from the displacement modes shown in Fig. 3.

$$U^i = -\frac{bsh_s}{4} U \dots\dots\dots(21)$$

$$\zeta^i = \frac{b_c}{2} \phi \dots\dots\dots(22)$$

$$v^i = \frac{h_s}{2} \phi \dots\dots\dots(23)$$

The joint forces acting on section i of the suspension bridge are shown in Fig. 7.

The equilibrium equation at the i -th joint of the left side cable toward the ξ direction is

$$-m_{ci} \xi_i^i - H_{pb_{i-1}}^{cl} - H_{pa_i}^{cl} - H_{pb_i}^{hl} = 0 \dots\dots(24a)$$

and that of the right side cable is

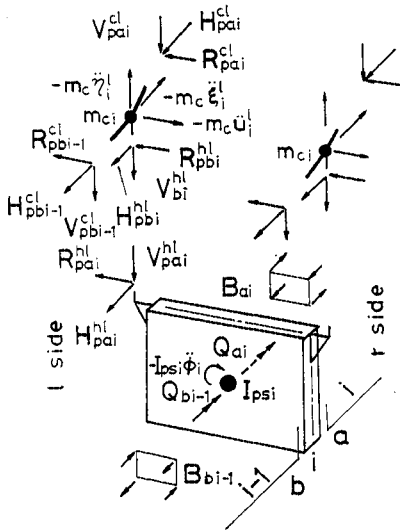

Fig. 7 Equilibrium at Section *i*.

$$-m_{ci} \ddot{x}_i^r - H_{pb_{i-1}}^{cr} - H_{p_{ai}}^{cr} - H_{pb_{i-1}}^{hr} = 0 \dots\dots(24b)$$

The above two Eqs. (24a) and (24b) coincide with each other utilizing Eqs. (19) and (20). Analogously, toward the η direction we have

$$-m_{ci} \ddot{\eta}_i^l - V_{pb_{i-1}}^{cl} - V_{p_{ai}}^{cl} - V_{pb_{i-1}}^{hl} = 0 \dots\dots(25)$$

At the *i*-th point of the left side cable, the equilibrium equation in the \ddot{u} direction is

$$-m_{ci} \ddot{u}_i^l - R_{pb_{i-1}}^{cl} - R_{p_{ai}}^{cl} - R_{pb_{i-1}}^{hl} = 0, \dots\dots(26a)$$

and that for the right side cable is

$$-m_{ci} \ddot{u}_i^r - R_{pb_{i-1}}^{cr} - R_{p_{ai}}^{cr} - R_{pb_{i-1}}^{hr} = 0 \dots\dots(26b)$$

Eqs. (26a) and (26b) also coincide with each other utilizing Eqs. (19) and (20).

From the equilibrium for the stiffening girder, the following equation is obtained.

$$\begin{aligned} -I_{psi} \ddot{\phi}_i - V_{p_{ai}}^{hl} \frac{b_0}{2} + V_{p_{ai}}^{hr} \frac{b_0}{2} - R_{p_{ai}}^{hl} \frac{h_s}{2} \\ - R_{p_{ai}}^{hr} \frac{h_s}{2} - Q_{bi-1} - Q_{ai} = 0 \dots\dots(27a) \end{aligned}$$

This equation, from Eqs. (19) and (20), reduces to

$$-I_{psi} \ddot{\phi}_i - b_c V_{p_{ai}}^{hl} - h_s R_{p_{ai}}^{hl} - Q_{bi-1} - Q_{ai} = 0 \dots\dots(27b)$$

The equilibrium equation for the bimoment of the stiffening girder will be

$$B_{bi-1} + B_{ai} - H_{p_{ai}}^{hl} \frac{b_c h_s}{4} + H_{p_{ai}}^{hr} \frac{b_c h_s}{4} = 0, \dots\dots(28a)$$

and can be reduced to

$$B_{bi-1} + B_{ai} - H_{p_{ai}}^{hl} \frac{b_c h_s}{2} = 0 \dots\dots(28b)$$

These equations will be transformed to expressions in the term of one bridge in order to utilize the structural matrix analysis method,

$$2m_{ci} \ddot{x}_i^l + 2H_{pb_{i-1}}^{cl} + 2H_{p_{ai}}^{cl} + 2H_{pb_{i-1}}^{hl} = 0 \dots\dots(29a)$$

$$2m_{ci} \ddot{\eta}_i^l + 2V_{pb_{i-1}}^{cl} + 2V_{p_{ai}}^{cl} + 2V_{pb_{i-1}}^{hl} = 0 \dots\dots(29b)$$

$$2m_{ci} \ddot{u}_i^l + 2R_{pb_{i-1}}^{cl} + 2R_{p_{ai}}^{cl} + 2R_{pb_{i-1}}^{hl} = 0 \dots\dots(29c)$$

$$-\frac{b_s h_s}{2} H_{p_{ai}}^{hl} + B_{bi-1} + B_{ai} = 0 \dots\dots(29d)$$

$$I_{psi} \ddot{\phi}_i + b_0 V_{p_{ai}}^{hl} + h_s R_{p_{ai}}^{hl} + Q_{bi-1} + Q_{ai} = 0 \dots\dots(29e)$$

Eqs. (29a)~(29e) can be arranged into the following matrix expressions:

$$\begin{aligned} 2m_{ci}[E]\{d\ddot{x}_i^{cl}\} + 2\{dF_{bi-1}\} + 2\{dF_{ai}^{cl}\} \\ + 2\{dF_{bi}^{hl}\} = \{0\} \dots\dots(30) \end{aligned}$$

$$\begin{aligned} [M_{si}]\{d\ddot{x}_i^s\} + 2[D_i]\{dF_{ai}^{hl}\} + \{dF_{bi}^{hl}\} \\ + \{dF_{ai}^s\} = \{0\} \dots\dots(31) \end{aligned}$$

where

[E]: unit matrix

$$[M_{si}] = \begin{bmatrix} 0 & 0 \\ 0 & I_{psi} \end{bmatrix}$$

$$[D_i] = \begin{bmatrix} -b_c h_s/4 & 0 & 0 \\ 0 & b_0/2 & h_s/2 \end{bmatrix}_i$$

$$\{d\ddot{x}_i^{cl}\} = [\ddot{x}_i^l, \ddot{\eta}_i^l, \ddot{u}_i^l]^T$$

$$\{d\ddot{x}_i^s\} = [U_i, \phi_i]^T$$

Thus, combining Eqs. (21), (22) and (23).

$$\begin{aligned} \{d\ddot{x}_{ai}^{hl}\} &= [U^l, \zeta^l, v^l]^T_i \\ &= \begin{bmatrix} -b_c h_s/4 & 0 \\ 0 & b_0/2 \\ 0 & h_s/2 \end{bmatrix}_i \begin{bmatrix} U_i \\ \phi_i \end{bmatrix}_i \\ &= [D_i]^T \{d\ddot{x}_i^s\} \dots\dots(32) \end{aligned}$$

Hence, Eqs. (30) and (31) are rewritten as follows,

$$\begin{aligned} [M_{oi}]\{d\ddot{x}_i^{cl}\} + \{dF_{bi-1}^{cl}\} + \{dF_{ai}^{cl}\} \\ + \{dF_{bi}^{hl}\} = \{0\} \dots\dots(33) \end{aligned}$$

$$\begin{aligned} [M_{si}]\{d\ddot{x}_i^s\} + \{dF_{ai}^{hl}\} + \{dF_{bi}^{hl}\} \\ + \{dF_{ai}^s\} = \{0\} \dots\dots(34) \end{aligned}$$

where

$$[M_o] = 2 \begin{bmatrix} m_{ci} & 0 & 0 \\ 0 & m_{ou} & 0 \\ 0 & 0 & m_{ov} \end{bmatrix}$$

$$\begin{aligned} \{dF^{cl}\} &= 2\{dF^{cl}\} \\ &= 2[k^c]\{d\ddot{x}^{cl}\} \\ &= [k^{cl}]\{d\ddot{x}^{cl}\} \end{aligned}$$

$$\{dF^{hl}\} = 2 \begin{bmatrix} [D] & [0] \\ [0] & [E] \end{bmatrix} \begin{Bmatrix} \{dF_{ai}^{hl}\} \\ \{dF_{bi}^{hl}\} \end{Bmatrix}$$

$$\begin{aligned}
 &= 2 \begin{bmatrix} [D] & [0] \\ [0] & [E] \end{bmatrix} [k^h] \begin{bmatrix} [D] & [0] \\ [0] & [E] \end{bmatrix} \begin{Bmatrix} \{dx^s\} \\ \{dx^{o1}\} \end{Bmatrix} \\
 &= [k^{ht}] \begin{Bmatrix} \{dx^s\} \\ \{dx^{o1}\} \end{Bmatrix}
 \end{aligned}$$

From Fig. 8 as well as Eqs. (33) and (34), it is found that an oscillation analysis for a suspension bridge is possible by the displacement method for plane framed structures with arbitrary configurations. In that analysis several assumptions are made, i.e. the cables and hangers are regarded as bars with tensions, and the stiffening truss is regarded as a beam (not beam-column) subjected to axial forces. Therefore, that analysis is theoretically applicable not only to suspension bridges but also to cable stayed bridges.

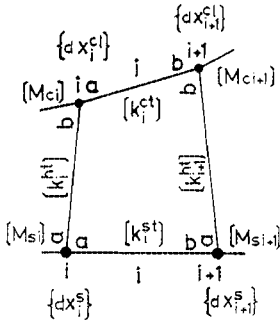

Fig. 8 Model for the Displacement Method.

The method of dynamic analysis for such a case relies on the ordinary method in the matrix method, for example, the one presented in reference 6).

So far almost all the effects including the longitudinal and transverse inertial masses of cable, the hanger elongation, and the hanger inclination have been taken into account. Thus, the number of independent degrees of freedom amounts to five per one section of the suspension bridge. When the following assumptions are added to the prescribed assumptions (1)~(6), the number of independent degrees of freedom becomes only one per one section of the bridge, and the analysis is simplified.

- Assumption 7: The elongation of hangers is neglected.
- Assumption 8: All the hangers are vertically suspended.
- Assumption 9: The hangers do not affect longitudinal restraints of the stiffening truss and cables.
- Assumption 10: The longitudinal inertial forces of cable are neglected.

Assumption 11: The transverse stiffness resistance of hangers and the transverse inertial forces of cables in the out-of-plane direction are neglected.

Although these conditions are easily processed by a computer program for Eqs. (33) and (34) using the matrix method, the following study will be presented and developed in order to investigate the meaning of these assumptions.

With these conditions, the equations corresponding to Eqs. (29a), (29b), (29d) and (29e) become as follows,

$$2H_{pb_{i-1}}^{c1} + 2H_{pa_i}^{c1} = 0 \dots\dots\dots(35a)$$

$$2m_{ci}\ddot{\eta}_i^t + 2V_{pb_{i-1}}^{c1} + 2V_{pa_i}^{c1} + 2V_{pb_i}^{h1} = 0 \dots(35b)$$

$$B_{b_{i-1}} + B_{a_i} = 0 \dots\dots\dots(35c)$$

$$I_{ps_i}\ddot{\phi}_i + b_c V_{pa_i}^{h1} + Q_{b_{i-1}} + Q_{a_i} = 0 \dots\dots\dots(35d)$$

When the following Eq. (36) holds, Eqs. (37) and (38) are derived

$$\begin{aligned}
 \{dF^{c1}\} &= [H_{pa}^{c1}, V_{pa}^{c1}, H_{pb}^{c1}, V_{pb}^{c1}]^T \\
 &= \{dF^{o1}\} \quad (\text{cf. Eq. (19)}) \\
 \{dx^{c1}\} &= [\xi_a^t, \eta_a^t, \xi_b^t, \eta_b^t]^T \\
 &= \{dx^{o1}\} \quad (\text{cf. Eq. (19)}) \\
 \{dF^{s1}\} &= [Q_a^s, B_a^s, B_b^s, Q_b^s]^T \quad (\text{Note; the order of elements in Eq. (18) is reversed.}) \\
 \{dx^{s1}\} &= [\phi_a, U_a, \phi_b, U_b]^T
 \end{aligned}$$

$$\dots\dots\dots(36)$$

$$\{dF^{o1}\} = [k^{o1}]\{dx^{o1}\} \dots\dots\dots(37)$$

$$\{dF^{s1}\} = [k^{s1}]\{dx^{s1}\} \dots\dots\dots(38)$$

where

$[k^{c1}]$: $[k^c]$ in Eq. (19), omitting elements regarding to displacement u

$[k^{s1}]$: $[k^s]$ in Eq. (18), but the order of elements has been changed

Since

$$V_{pa_i}^{h1} = -V_{pb_{i-1}}^{h1}, \dots\dots\dots(39)$$

eliminating hanger terms from Eqs. (35b) and (35d) gives

$$\begin{aligned}
 m_{ci}b_c\ddot{\eta}_i^t + I_{ps_i}\ddot{\phi}_i + b_c(V_{pb_{i-1}}^{c1} + V_{pa_i}^{c1}) \\
 + Q_{b_{i-1}} + Q_{a_i} = 0 \dots\dots\dots(40a)
 \end{aligned}$$

Because of the continuity of displacements by assumption 7, it is found

$$\eta^t = \frac{b_c}{2}\phi \dots\dots\dots(41)$$

Thus Eq. (40a) becomes

$$\begin{aligned}
 \left(\frac{b_c^2}{2}m_c + I_{ps}\right)_i\ddot{\phi}_i + b_c(V_{pb_{i-1}}^{c1} + V_{pa_i}^{c1}) \\
 + Q_{b_{i-1}} + Q_{a_i} = 0 \dots\dots\dots(40b)
 \end{aligned}$$

When the notation

$$H_p' = 2H_p^{ci} \dots\dots\dots(42)$$

is introduced for the convenience of derivation, Eq. (35a) becomes

$$H_{p'bi-1} + H_{p'ai} = 0 \dots\dots\dots(43)$$

Eqs. (43), (40b) and (35c) are the basic equation of the problem concerned.

From Eq. (41)

$$\{dx^{c1}\} = [R^1]\{dx^{c2}\} \dots\dots\dots(44)$$

where

$$\{dx^{c2}\} = [\xi_a^i, \phi_a, \xi_b^i, \phi_b]^T$$

$$[R^1] = [\text{diagonal } (1, b_0/2, 1, b_0/2)]$$

If H_p^{ci} is transformed into H_p' , and V_p^{ci} is transformed into Q by multiplying b_0 , we get

$$\{dF^{c2}\} = 2[R^1]\{dF^{c1}\} \dots\dots\dots(45)$$

where

$$\{dF^{c2}\} = [H_a', Q_a^i, H_b', Q_b^i]^T$$

Substituting Eq. (37) into Eq. (45) gives

$$\{dF^{c2}\} = [k^{c2}]\{dx^{c2}\} \dots\dots\dots(46)$$

where

$$[k^{c2}] = 2[R^1][k^{c1}][R^1]$$

The next operation will be done in order to arrange the displacements in the cable and stiffening truss.

As to the cable, the stiffness equation is

$$\{dF^B\} = [k^{B2}]\{dx^B\} \dots\dots\dots(47)$$

where

$$\{dF^B\} = [H_a', Q_a, B_a, H_b', Q_b, B_b]^T$$

$$\{dx^B\} = [\xi_a^i, \phi_a, U_a, \xi_b^i, \phi_b, U_b]^T$$

$$[k^{B2}] = \begin{bmatrix} k_{11}^{B2} & k_{12}^{B2} & 0 & k_{13}^{B2} & k_{14}^{B2} & 0 \\ k_{21}^{B2} & k_{22}^{B2} & 0 & k_{23}^{B2} & k_{24}^{B2} & 0 \\ 0 & 0 & 0 & 0 & 0 & 0 \\ k_{31}^{B2} & k_{32}^{B2} & 0 & k_{33}^{B2} & k_{34}^{B2} & 0 \\ k_{41}^{B2} & k_{42}^{B2} & 0 & k_{43}^{B2} & k_{44}^{B2} & 0 \\ 0 & 0 & 0 & 0 & 0 & 0 \end{bmatrix}$$

and concerning the stiffening truss

$$\{dF^B\} = [k^{B2}]\{dx^B\} \dots\dots\dots(48)$$

where

$$[k^{B2}] = \begin{bmatrix} 0 & 0 & 0 & 0 & 0 & 0 \\ 0 & k_{11}^{B2} & k_{12}^{B2} & 0 & k_{13}^{B2} & k_{14}^{B2} \\ 0 & k_{21}^{B2} & k_{22}^{B2} & 0 & k_{23}^{B2} & k_{24}^{B2} \\ 0 & 0 & 0 & 0 & 0 & 0 \\ 0 & k_{31}^{B2} & k_{32}^{B2} & 0 & k_{33}^{B2} & k_{34}^{B2} \\ 0 & k_{41}^{B2} & k_{42}^{B2} & 0 & k_{43}^{B2} & k_{44}^{B2} \end{bmatrix}$$

The combined stiffness equation for both the cable and the stiffening truss is obtained by adding the two equations, that is,

$$\{dF^B\} = [k^B]\{dx^B\} \dots\dots\dots(49)$$

where

$$[k^B] = [k^{c2}] + [k^{B2}] \dots\dots\dots(50)$$

Matrix expression of Eqs. (35c), (40b) and (43) with the above notations gives

$$[M_i]\{dx_i^B\} + \{dF_{vi-1}^B\} + \{dF_{ai}^B\} = 0 \dots\dots\dots(51)$$

where

$$[M_i] = \begin{bmatrix} 0 & 0 & 0 \\ 0 & I_{psi} + b_c^2 m_{ci}/2 & 0 \\ 0 & 0 & 0 \end{bmatrix}$$

From Eq. (50), it is found that we can analyze the case even if the stiffening truss partially exists during an erection stage.

4. CONSIDERATION BY NUMERICAL CALCULATIONS

The design factors of suspension bridges vary widely according to design methods, loads, natural conditions, etc. So the effects of various design factors on the torsional frequencies may be different for individual bridges. In this paper, a bridge which is regarded as a standard long span suspension bridge with a center span length of

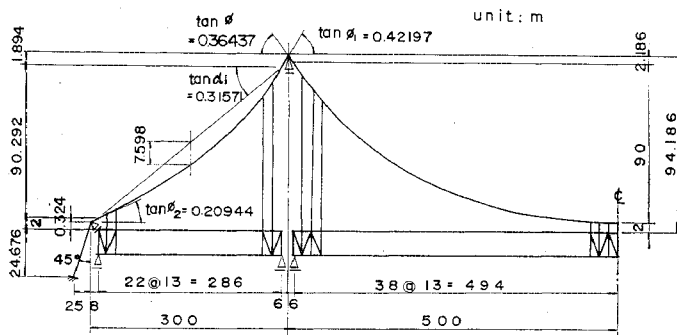

Fig. 9 Two-Hinged Suspension Bridge.

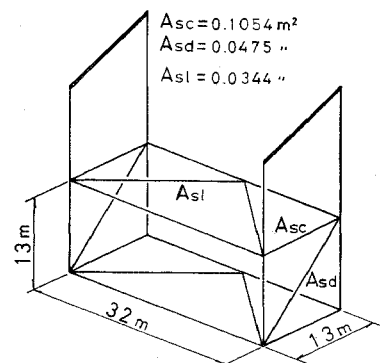

Fig. 10 Stiffening Truss Data.

about 1,000 m is adopted. The influences of the design factors of the bridge will be studied, compared with the results by conventional methods.

Numerical calculations are performed with a two-hinged suspension bridge having span lengths

300 - 1,000 - 300 m adopted in reference 14) and shown in Figs. 9 and 10. The member properties and the dead loads are shown in Tables 2 and 3, respectively. The moments of inertia of stiffening truss and cables are shown in Table 4,

Table 2 Properties of Members.

(per one side of br.)

Member	Terms	Value
Cable	E_c	$2.0 \times 10^7 \text{ t/m}^2$
	A_c	0.75398 m^2
Hanger	E_h	$1.4 \times 10^7 \text{ t/m}^2$
	A_h *1	0.01621 m^2
Stiffening truss	E_s	$2.1 \times 10^7 \text{ t/m}^2$
	G_s	$8.1 \times 10^6 \text{ t/m}^2$
	t_b	$2.117 \times 10^{-3} \text{ m}$
	t_h	$3.349 \times 10^{-3} \text{ m}$
	$G_s J_s$	$1.475 \times 10^8 \text{ t/m}^2$
	a_w	$9.576 \times 10^{10} \text{ t/m}^4$

Note *1: per one hanger every 13 m interval.

Table 3 Dead Loads.

(per one side)

Member	Center span	Side span	Direction
Cable	6.3102 t/m	6.2995 t/m	cable direction
	6.4471 t/m	6.6164 t/m	horizontal direc.
Stiffening truss	16.0 t/m	16.0 t/m	horizontal direc.

Table 4 Moment of Inertia.

(per one br.)

Member	Center span	Side span
Stiffening truss	9 200 tm^2/m	9 200 tm^2/m
Cable	3 301 "	3 388 "
Total	12 501 "	12 588 "

Table 5 Calculated Cases.

Case	m_{cx}	m_{cy}	m_{cz}	Center-stay	Spring const. of tower	T_w^c	T_w^h	Degrees of freedom	Compu. program	Description
1	—	○	—	—	—	T_w^c	—	17	A	The number of degrees of freedom per one section is one.
2	—	○	—	—	—	T_w^c	—	37	"	The number of divisions is two times that of case 1.
3	—	○	—	—	—	T_w^c	○	34	"	The hanger elongation is considered in case 1.
4	○	○	—	—	—	T_w^c	○	53	"	The longitudinal inertial forces of cables are considered in case 3.
5	○	○	—	stay	—	T_w^c	○	53	"	Center-stays are equipped in case 4.
6	○	○	—	tie	—	T_w^c	○	53	"	Center-ties are equipped in case 4.
7	—	○	—	—	—	$T_w^c \cos^2 \alpha_w$	○	34	"	The cable equation is Melan's equation in case 3.
8	○	○	—	—	○	T_w^c	○	53	"	Spring constants of towers are considered in case 4.
9	○	○	—	stay	○	T_w^c	○	53	"	Center-stays and spring constants of towers are considered in case 4.
10	—	○	○	—	—	T_w^c	○	53	"	Out-of-plane, transverse, resistance of hangers is considered in case 3.
11	—	○	—	—	—	$T_w^c \cos^2 \alpha_w$	—	17	B	Differential equation method for the deflection theory is used.
12	—	○	—	—	—	$T_w^c \cos^2 \alpha_w$	—	10	C	Rayleigh-Ritz method for the deflection theory is used.
13	○	○	—	stay	—	$T_w^c \cos^2 \alpha_w$	—	17	B	Center-stays are equipped in case 11.

Notes: m_{cx} , m_{cy} , m_{cz} =longitudinal, vertical, transverse (toward out-of-plane direction) inertial masses of the cables, respectively.

T_w^c , T_w^h =tensile forces of the cables and the hangers due to dead loads, respectively.

and the new equilibrium configuration under the dead loads has already been calculated by the finite deformation theory program, which is shown in Fig. 11. The conditions of calculation cases are shown in Table 5. Inertial masses m_{cx} , m_{cy} are neglected in some cases.

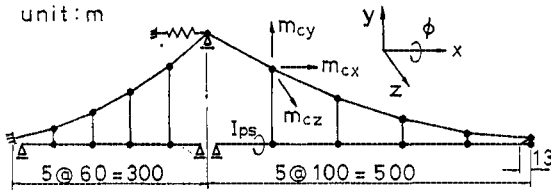

Fig. 11 Oscillation Model of the Suspension Bridge.

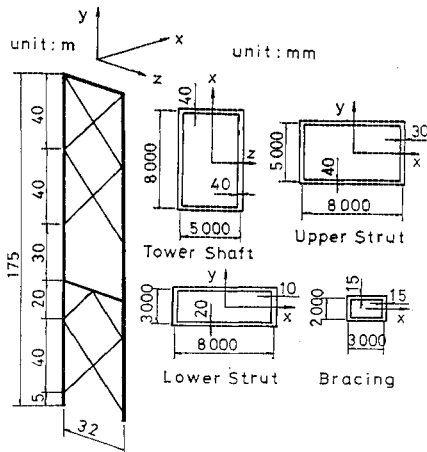

Fig. 12 Tower Model.

In Cases 5 and 9, the sectional area 0.012968 m^2 of the center-stay member is comparable to the original design. In Case 6 the sectional area of the center-stay member is enlarged 100 times

that of Case 5, which is regarded as a center-tie.

In Cases 8 and 9, the tower configuration and the member sections are assumed as shown in Fig. 12. Torsional forces to obtain the spring constant of the tower is shown in Fig. 13. There are two ways to estimate it. One is that all members are assumed to be beams with sectional area, moment of inertia of area and St. Venant's torsional rigidity. Alternatively, it is assumed that the tower shafts are beam-columns and the other members are the above-mentioned beams.

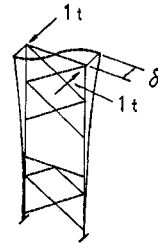

Fig. 13 Torsional Forces for the Tower.

In the former case the spring constant is $2.09 \times 10^8 \text{ t/m}$ per one side of bridge and that in the latter case is $1.923 \times 10^8 \text{ t/m}$ per one side of bridge. The former value is used in Cases 8 and 9.

In Table 5, computer program A(XHONSIK/DYNSPACE) was prepared on the basis of the present theory by the authors. The calculation time in Case 4 was about 140 seconds by Burroughs B6700. Program B was based on linearized Melan's equation and the cable equation. The torsional rigidities are evaluated by Bleich's method¹³. The hangers are assumed to be a membrane without shear resistance. This method is fundamentally identical to that presented in reference 8). Program C was made by utilizing the equations presented in reference 4), and 6

Table 6 Comparison of Periods (second).

Cases		1	2	3	4	5	6	7	8	9	10	11	12	13
1	First symmetric	3.877	3.865	3.863	3.871	3.874	3.874	3.874	3.848	3.862	3.855	3.892	3.850	3.892
2	First asymmetric	2.797	2.768	2.774	2.817	2.695	2.588	2.781	2.817	2.586	2.766	2.748	2.748	2.468
3	Second symmetric	1.883	1.840	1.873	1.887	1.890	1.888	1.877	1.886	1.887	1.870	1.829	1.811	1.829
4	Side span (asym.)	1.670	1.650	1.618	1.646	1.621	1.596	1.625	1.639	1.595	1.617	1.579	1.578	1.536
5	Side span (sym.)	1.612	1.591	1.571	1.589	1.589	1.589	1.578	1.588	1.588	1.570	1.536	1.531	1.536
6	Second asymmetric	1.440	1.383	1.440	1.453	1.440	1.437	1.443	1.453	1.437	1.438	1.391	1.357	1.391
7	Third symmetric	1.186	1.107	1.181	1.190	1.189	1.186	1.184	1.190	1.186	1.180	1.126	1.075	1.126
8	Third asymmetric	1.025	0.925	1.020	1.028	1.020	1.020	1.022	1.028	1.020	1.019	0.959	0.887	0.958

terms in the center span and 4 terms in the side span are considered from the sine series.

Calculated results are shown in Table 6. In program A of the table, the QR method is used to obtain the characteristic values, the accuracy of which was better than 10^{-5} seconds in periods. Therefore, it may be concluded that the differences of periods in Table 6 are due to factors considered in each case where number of degrees of freedom is identical.

The following are observed from Table 6.

- 1) The influence of hanger intervals can be seen by comparing Case 1 with Case 2. The difference of periods is only 1~2% in low modes which are the most influential in the design of a bridge, so the same hanger intervals as in Case 1 are used in the following cases.
- 2) The effect of the longitudinal resistance of hangers is shown in Case 1 and Case 3. The periods in Case 3 are a little shorter than those in Case 1, namely, one can not expect the large effect of hanger resistance between cable and girder.
- 3) The influence of longitudinal inertial mass of cable, m_{ox} can be found by comparing Case 4 with Case 3. It hardly affects the periods of symmetric modes, but increases the period by as much as 1.5% in the first symmetric mode.
- 4) The influence of the center-stay is seen by comparing Case 5 with Case 4. The center-stay hardly affects the periods in the symmetric mode, but decreases the period by as much as 4.3% in the first asymmetric mode.
- 5) As it is seen by a comparison between Cases 6 and 4, the effect of the center-tie on the periods of natural vibrations is larger in all cases. The center-tie hardly affects the periods of symmetric mode, but decreases the period by as much as 8.1% in the first asymmetric mode. It should be noted that this effect can be obtained if the sectional area of the center-tie is larger than the sectional area of cable, and it becomes about half if a practical member area is used as shown in Case 5. In the conventional theories, the connection of the center-stay or tie between cables and stiffening girder or truss has been assumed to be rigid. Case 13 shows the result by the differential equation method which is the same as that of Case 11. In this case, the effect of the center-stay reduces the period in the first asymmetric mode by as much as 11% compared with Case 11 or 14% compared with Case 4. Therefore, there is the possibility of an unfavorable estimation of periods for a practical structure.
- 6) Comparing Case 4 with Case 8, the influence of the spring constants of the tower is found to be little in both the symmetric and the asymmetric modes. Consequently, the effect of the spring constants of the tower alone should not be expected in long-span suspension bridges.
- 7) It has been said that⁴⁾ torsional frequencies of suspension bridges with a center-stay or center-tie are greatly affected whether or not one takes into account torsional rigidities of the towers. In Case 9, the effects of both the spring constants of the towers and the center-stay are taken into consideration. Comparing Case 9 with Case 6 (with center-tie), both effects are almost the same degree. Although the case, in which both the center-tie and the spring constants of the towers exist, is not treated, the effects of those are expected to be larger than in Case 9.
- 8) The influence of the out-of-plane, transverse resistance of hangers is indicated by comparison of Case 10 with Case 3. By virtue of its little influence, one may be allowed not to take into account the effect of such a resistance in future calculations.
- 9) The influence of decreasing cable tensions by as much as $\cos^2 \alpha_w$ times in Melan's equation is found to be very little by comparing Case 7 with Case 3.
- 10) Comparing Case 11 and Case 12 with Case 2, both the differential equation method and the Reyleigh-Ritz method for the equations of the deflection theory show good approximation in the absence of a center-stay.

5. CONCLUSION

- 1) With the aid of the thin-walled elastic beam theory by Vlasov, a torsional stiffness equation for a stiffening truss with a biaxially symmetric and rigid cross section has been derived as shown in Eq. (18).
- 2) Bi-moment of a truss is estimated practically as the balance of force between truss, hangers and cables. Thus, influences of diagonal hangers, center-stay or tie, longitudinal inertial masses of cable, etc. can be analyzed more easily and correctly than has ever been done before.
- 3) The matrix method is used for the torsional oscillation analysis of suspension bridges. The stiffness equation of such a bar member subjected to axial forces as cables, and the stiffness equation for a stiffening truss are firstly derived. This method is applicable to the torsional oscillation analysis for arbitrary suspension bridges, both during erection and in completed stages.

4) In long span suspension bridges without a center-stay, it is permissible to neglect the influences of longitudinal inertial masses of cables and out-of-plane, transverse resistance of hangers for the estimation of torsional oscillation periods.

5) When a center-stay is equipped in a suspension bridge, the torsional oscillation periods should be calculated with the practical cross sectional area and lengths of the center-stay members, considering the spring effect of the tower and longitudinal, inertial masses of cable. If the analysis is made with a rigid connection condition as in the conventional theories, one may get an unfavorable estimation for periods, namely shorter periods than the true ones.

6) In calculating the torsional oscillation periods of a suspension bridge without a center-stay, the conventional methods based on the deflection theory including the Rayleigh-Ritz method have sufficient accuracy.

ACKNOWLEDGEMENT

The authors appreciate Mr. T. Okamoto of Sogo Engineering Consultants Inc. for his help in the derivation of the stiffness equation of stiffening truss and Mr. Y. Morita of Long Span Bridge Consultants Inc. for his help in the numerical calculations of the deflection theory, and we also thank Dr. M. Ito of the University of Tokyo for his useful advice and Dr. J. Tajima and other people of Honshu-Shikoku Bridge Authority who have encouraged the authors to study this work.

NOTATION

on Co-ordinates

(s, ξ_s, u_s) : Local co-ordinates in box girder (Fig. 2)

(x, y, z) : Global co-ordinates

on Dimension

A_{sc}, A_{sd}, A_{st} : Cross-sectional areas of stiffening truss members

A_c : Cross-sectional area of one cable

A_h : Cross-sectional area of one hanger used in its stiffness matrix

b_o : Distance between cables

b_s : Width of stiffening truss

$h(h_o)$: Strained (unstrained) length of hanger

h_s : Height of stiffening truss

(l, m, n) : Direction cosines of cable under dead loads

l_f : Joint interval of stiffening truss

$L(L_o)$: Strained (unstrained) length of cable used in its stiffness matrix

t_b, t_h : Equivalent thicknesses of lateral and main system in stiffening truss

on Displacement

(ξ, η, u) : Components of joint displacement of cable (Fig. 5)

(U', ζ', v') : Components of joint displacement of hanger connected to stiffening truss (Fig. 5)

U : Generalized warping of stiffening truss (Fig. 3)

ϕ : Rotation angle of stiffening truss (Fig. 3)

θ : Generalized cross-sectional distortion angle of stiffening truss (Fig. 3)

on Force

B : Longitudinal bimoment of stiffening truss

(H_p^c, V_p^c, R_p^c) : Components of joint force increment of cable (Fig. 6)

(H_p^h, V_p^h, R_p^h) : Components of joint force increment of hanger (Fig. 6)

$H_p' = 2H_p^c$

Q : Torsional moments of stiffening truss

T_w^c : Cable tension due to dead loads

T_w^h : Hanger tension due to dead loads

X : Transverse bimoment of stiffening truss

on Mass

I_{ps} : Joint moment of inertia of stiffening truss

m_o : Joint mass of one cable

on Stiffness

a_w : Generalized warping rigidity of stiffening truss

E_c, E_h, E_s : Modulus of elasticity relating to cable, hanger and stiffening truss, respectively

G_s : Modulus of transverse elasticity relating to stiffening truss

$G_s J_s$: St. Venant's torsional rigidity of stiffening truss

on Subscript (under the foot or on the shoulder of letter)

a, b : Distinguishing member ends

c : Referring to cable

h : Referring to hanger

i : Number of joint or member

l : Denoting left side

p : Denoting force increment

r : Denoting right side

- s : Referring to stiffening truss
 w : Denoting condition under dead loads

REFERENCES

- 1) Bleich, F. et al.: The Mathematical Theory of Vibration in Suspension Bridges, United States Government Printing Office, 1950.
- 2) Selberg, A.: Oscillation and Aerodynamic Stability of Suspension Bridges, Acta Polytechnica Scandinavica, UDC 624.5 : 534.1, Norwegian Contribution No. 13, 1961, pp. 26-36.
- 3) Vlasov, V. Z.: Thin-Walled Elastic Beams, Israel Program for Scientific Translation, Jerusalem, 1961.
- 4) Hirai, A.: Steel Bridges III, Gihodo, 1967, pp. 435-439, (in Japanese).
- 5) Tezcan, S. S. and Cherry, S.: Earthquake Analysis of Suspension Bridges, the Fourth World Conference on Earthquake Engineering, Chile, Jan., 1969.
- 6) Clough, R. W.: Analysis of Structural Vibrations and Dynamic Response, Recent advances in matrix methods of structural analysis and design, U. of Alabama press, 1970.
- 7) Shiraki, K., Fukuzawa, K., Tanaka, H. and Matsui, Y.: Aerodynamic Instability in Suspension Bridge under Erection, Mitsubishi Heavy Industries Technical Review, Vol. 7, No. 7, 1970, pp. 957-967, (in Japanese).
- 8) Aoyagi, S.: On the Response of Long Span Suspension Bridges Subjected to Earthquake Different between Substructures, Proc. JSCE, No. 190, 1971, pp. 37-48, (in Japanese).
- 9) Komatsu, S. and Nishimura, N.: Torsional Oscillation Analysis of Suspension Bridges under the Consideration of Cross Sectional Distortion in Suspended Structure. Analysis of Arches and Supplement for the Analysis of Suspension Super-Structure, Committee Reports on the Analysis for the Honshu-Shikoku Connecting Bridges, No. 4, JSCE, 1974, pp. 58-70, (in Japanese).
- 10) Komatsu, S. and Nishimura, N.: Three Dimensional Analysis of Suspension Bridges under the Consideration of Cross-Sectional Distortion in Suspended Structure, Proc. JSCE, No. 236, April, 1975, pp. 15-29, (in Japanese).
- 11) Hayashi, Y. and Murata, M.: Torsional Oscillation Analysis of Suspension Bridges, Proc. Annual Meeting of JSCE (29th), Part I, 1974, pp. 499-500, (in Japanese).
- 12) Murata, M. and Hayashi, Y.: Torsional Oscillation Analysis of Suspension Bridges (Second Report), Proc. Annual Meeting of JSCE (30th), Part I, 1975, (in Japanese).
- 13) Hayashi, Y., Higuchi, K. and Tanaka, Y.: Three Dimensional Analysis of Truss Girders by the Thin-Walled Elastic Beam Theory considering Cross-Sectional Deformations, Proc. JSCE, No. 249, 1976, (in Japanese).
- 14) Hayashi, Y.: Linearized Finite Deformation Theory in Suspension Bridges, Proc. JSCE, No. 257, 1977.

(Received March 22, 1976)

MARUI

MIV-4600 電気油圧サーボシステム

電気油圧式 振動疲労試験機

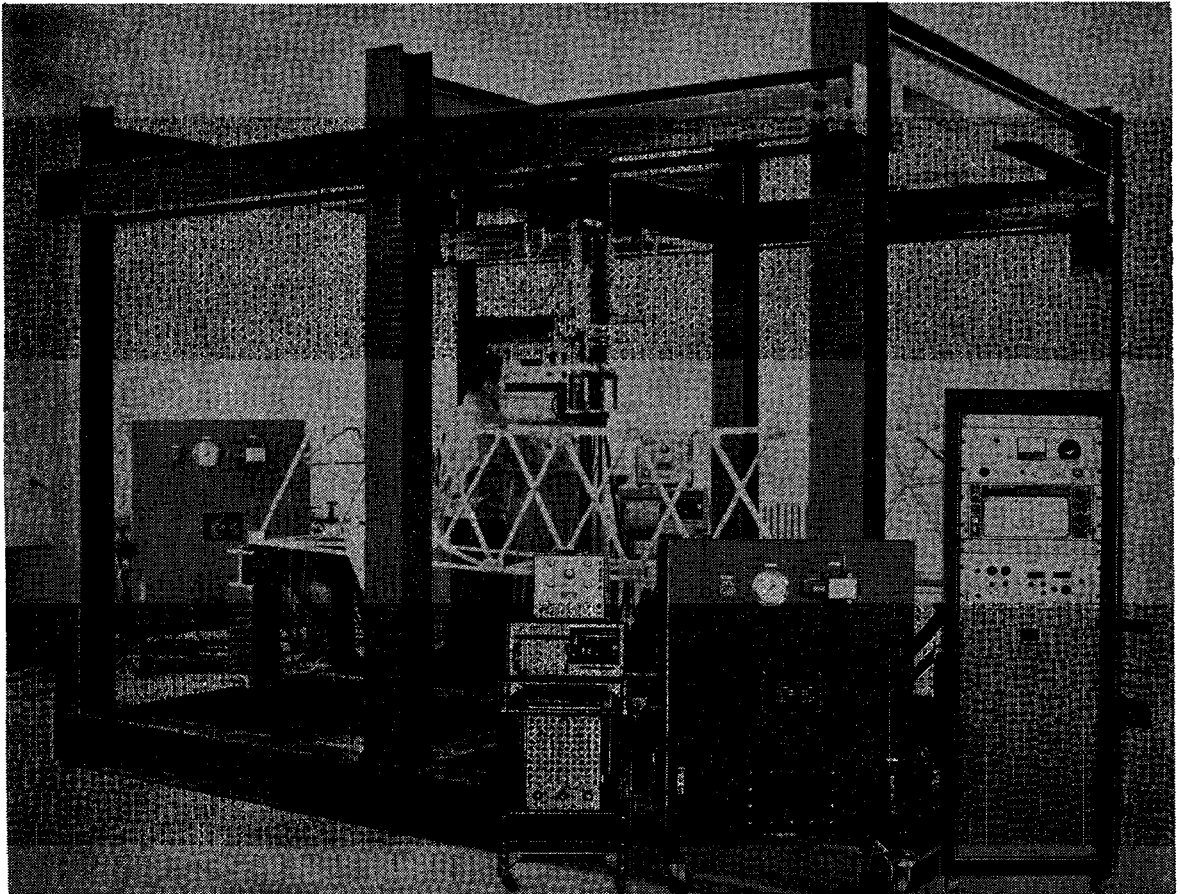

MIV-4600シリーズは中小規模・材料・構造物・構造物模型
部品等の実働波による振動・疲労試験に最適品です。

特長 ◆振動、疲労波形を任意の波形運転することができます。

(正弦・三角・矩形・複合・ランダム・磁気テープ入力による運転も可能)

- ◆制御方式を広い範囲に選択することができます(荷重・変位・加速度の制御が可能)
- ◆複数の加振器を組合せて同時に運転できます(振巾・位相等を変えて運転が可能)
- ◆出力は±50ton～±100kg各種製造いたしています。
- ◆任意の場所で設置し試験が可能です。



土木建築用材料試験機

株式会社

マルイ

東京営業所 東京都港区芝公園2丁目9-12 ☎東京 (03) 434-4717
大阪営業所 大阪市城東区蒲生町4丁目15 ☎大阪 (06) 934-1021
名古屋営業所 名古屋市中村区牧野町5丁目10 ☎名古屋 (052) 452-1381
九州営業所 福岡市博多区比恵町4番17 ☎福岡 (092) 411-0950

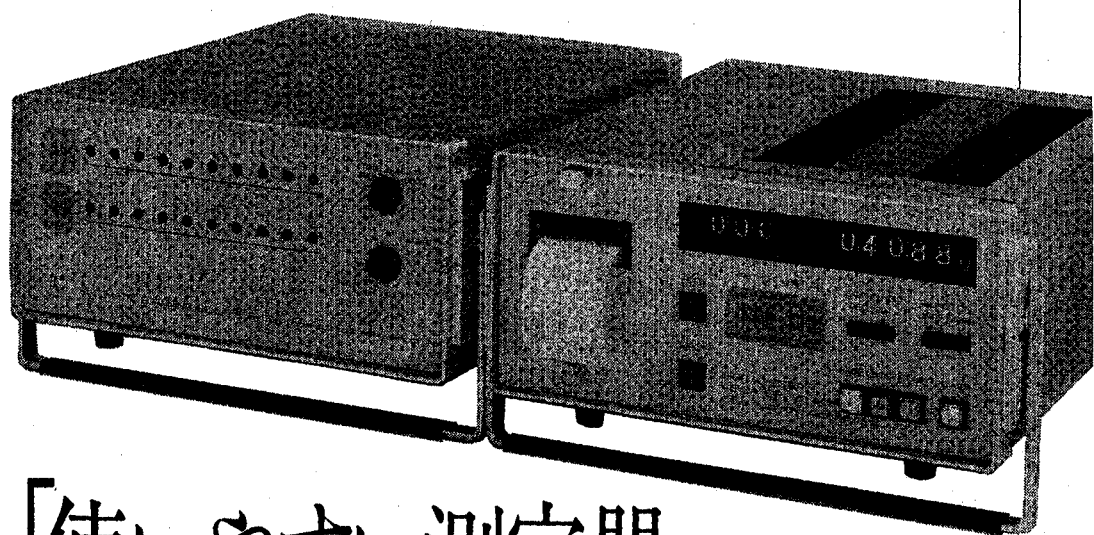

「使いやすい測定器」と
ご好評をいただいております。

初期値記憶式—バランス調整不要

共和の携帯型デジタルひずみ測定器
SD-500A, ASB-50A

計測開始時に測定点の初期不平衡出力をコアメモリに記憶し、次に負荷時のひずみを測定し、すでに記憶している初期不平衡分とを演算し、真のひずみを求めます。ひずみ値は、デジタル表示すると共に、内蔵プリンタでプリントアウトします。
小型、軽量、可搬型で現場用。実験室用としてラックタイプもあります。また自動無人計測用のオプション機器の準備があり、データ解析処理のためのパーソナルコンピュータにも接続できます。

- 特長
- 調整時間が大幅に短縮できる
 - 計測時間は1点あたり0.5秒以下
 - 直流ブリッジ電源採用により、高精度な測定ができる
 - 測定点の開始、終了の任意設定可能
 - オプション機器が豊富

- 仕様
- 測定範囲.....0~±39999×10⁻⁶ひずみ
 - 計測時間.....0.5秒/点
 - 多点切換点数.....20点(カスケード接続10台)
50点(カスケード接続4台)
 - ゲージブリッジ.....
 - 回路切換.....1、2、4枚ゲージ法、全点共通または単独切換
 - 精度.....±(指示値0.1%+2数値)
 - 電源.....AC100V
 - 寸法.....350×160×400mm

- オプション機器
- デジタルクロック ASC-50A
 - スタータ AST-50A
 - 紙テープさん孔装置 OPC-50A
 - ケーブルアダプタ

未来をひらく電子計測器メーカー
株式会社 共和電業

- 本社・工場
東京都調布市調布ヶ丘3の5の1
電話=0424-87-2111(大代)
- 東京営業所
東京都港区芝西久保明舟町19
電話=03-502-3551(大代)
- 大阪営業所
大阪市東区森之宮東之町544(三双ビル)
電話=06-942-2661(代)
- 名古屋営業所
名古屋市千種区田代町字瓶杖1の57(東山大木ビル)
電話=052-782-2521(代)
- 福岡営業所
福岡市博多区博多駅東2の5の20(松永ビル)
電話=092-411-6744(代)
- 広島営業所
広島市東白島町5の9(くにまきビル)
電話=0822-21-9536
- 札幌営業所
札幌市中央区南四条西9丁目(観光ビル)
電話=011-261-7629
- 水戸営業所
水戸市上水戸2の6の5
電話=0292-25-1074